

No. 6 September 1983

IMAGINE™

Adventure Games Magazine

£1.00

- ★ **The Thief Acrobat**
a new split class for the
light-fingered
- ★ **Jack Of All Trades**
a scenario for the
D&D®, AD&D™ and
DRAGONQUEST™
games
- ★ **Dome of Whispers**
adventure fiction by Ian
Watson



Watch Out!
There's a THIEF about.

EMMANUEL '83

RELIVE THE ROARING 20'S

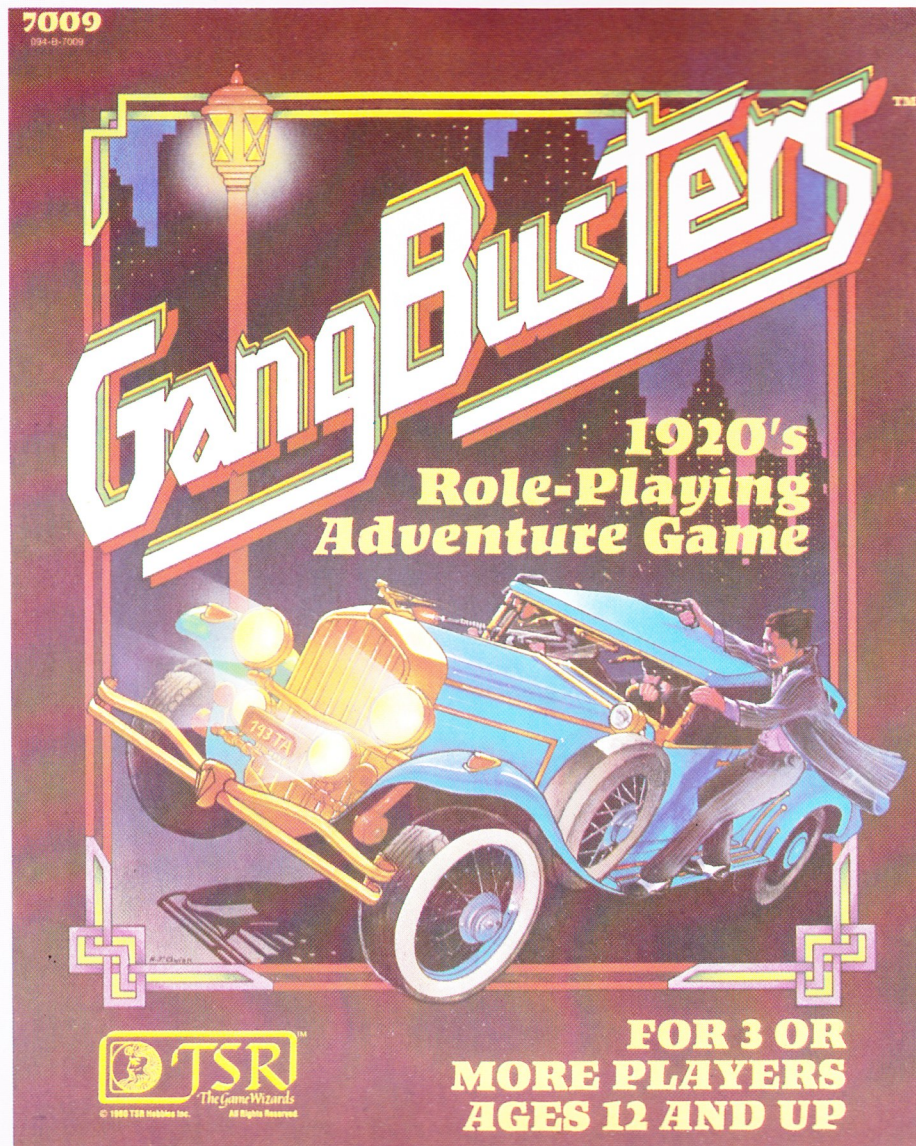

Relive the days of the 'Untouchables', when G-men battled gangsters. Be a private eye . . . or reporter . . . your choice of colourful characters in an era of mobsters and bootlegging. Players in the GANGBUSTERS™ game investigate the underworld of Lakefront City — a fictional metropolis in the 'Roaring Twenties' and 'Troubled Thirties'. The GANGBUSTERS™ game includes a 64 page rulebook, a 16 page module, dice, a sheet of counters, and maps of Lakefront City. In the TSR tradition, the GANGBUSTERS™ role playing game will be supported by a range of exciting and challenging modules.

**HISTORY IN THE MAKING
FROM**

The symbol ™ represents trade marks owned by TSR Hobbies (Inc).



TSR Hobbies (UK) Ltd,
The Mill, Rathmore Road,
Cambridge CB1 4AD
Tel: (0223) 212517



IMAGINE™



Editorial

No. 6 September 1983

Published by
TSR UK Ltd

Publisher Don Turnbull
Editor Keith Thomson
Assistant Editor Paul Cockburn
Editorial Assistant Kim Daniel
Features Assistant Mike Brunton
Art Phil Kaye

This month's contributing artists:

Emmanuel Paul Ruiz
Ian Williamson Anne Hamill
Pete Young Jeremy Goodwin
Sarah Hocombe

IMAGINE™ magazine is published monthly by TSR UK Ltd, The Mill, Rathmore Road, CAMBRIDGE CB1 4AD. Telephone: (0223) 212517. Telex: 818761.

IMAGINE magazine is available from all good hobby shops and newsagents. It is also available direct from the publisher by individual subscription. The subscription rate is £12 for twelve issues.

Back issues of IMAGINE magazine, where still available, can be bought directly from the publisher for the price of £1.50 (inc postage and packing). Payment must accompany all orders. If one or more issues in an order are out of print, a credit note will be substituted which may be exchanged for cash or merchandise from the publisher.

The issue of expiration for each subscription will be printed on the subscriber's mailing label. Changes of address must be notified to the publisher at least 30 days before the effective change to ensure uninterrupted delivery.

All material published in IMAGINE magazine becomes the exclusive property of the publisher prior to publication, unless special arrangements are made to the contrary in writing.

IMAGINE magazine welcomes unsolicited submissions of written material and artwork at all times. However, no submissions will be returned unless accompanied by a stamped, self-addressed envelope of sufficient size. Under no circumstances will the publisher accept responsibility for any such submissions. Published material will be paid for.

IMAGINE is a trade mark owned by TSR Inc. All rights on the publication of this magazine are reserved, and nothing may be reproduced in whole or in part without the written consent of the publisher. Copyright ©1983 by TSR UK Ltd.

IMAGINE magazine gratefully acknowledges the support offered by its sister publication, DRAGON® magazine, published by our parent company TSR Inc, PO Box 756, Lake Geneva, Wisconsin 53147, USA. Articles appearing in IMAGINE magazine may have previously appeared in that publication.

Once again our modest and unassuming editor has stepped aside and allowed one of more humble rank to pen these words. Why he thought I would be ideal for writing the editorial for the 'Thieves' issue, I don't know....

This issue carries the Thief-Acrobat class for the AD&D™ game, part of the expansion of the game that has already seen the publication of the **Monster Manual 2** book this summer. Our colonial sister publication, DRAGON™ magazine, has carried many other additions, most of which have found or will find their way into revisions of the rules books. The Cavalier class, which we are expecting to publish in #12 of IMAGINE™ magazine, features many of the changes that are envisaged for the fighter classes. I look forward to hearing what you think of the Thief Acrobat and the Cavalier; notwithstanding the mail we had concerning the Barbarian!

At a time when the D&D® game has become the best-selling game in the UK, ahead of **Scrabble** and **Monopoly**, many of the more experienced players are asking 'where is the game going?' They can remember when it was a part of a hobby with a few hundred adherents — serious gamers with an interest that went beyond the mere *playing* of the game. Now, when many thousands are discovering role-playing for the first time, and when the AD&D game is being expanded through a variety of 'official' and 'unofficial' media, these long-serving gamers are asking what common ground there can be between them and the game they play, and the newcomers and their versions.

In the end, no matter what role-playing game you play or how you play it, you, the reader of this magazine, are a participant in a hobby dependent upon inspiration and imagination. You buy a cold set of rules — you transform it into a living world, with a consistent sense of its own 'reality'. We are aware that not everything that is currently being added to or called the AD&D game will find its way into every campaign. But give things a try first, and then tell us what you think.

Paul Cockburn

Contents

| | |
|---|-------|
| The Beginners' Guide to Role-Playing Games, our feature for the new player, with Nic Novice | 2 |
| Stirge Corner, by Roger Musson, a guide for the inexperienced player | 5 |
| The Thief-Acrobat, by Gary Gygas, a new split class for characters with high strength and dexterity ... | 7 |
| Dome of Whispers, by Ian Watson, original adventure fiction | 11 |
| Illuminations, news from the world of games | 19 |
| Jack of All Trades, by Roger Hall, a scenario for the D&D, AD&D and DRAGONQUEST™ games..... | 21 |
| Players Association News, a magazine within a magazine, edited by Mike Brunton | |
| PAN Pipings | 31 |
| Dispel Confusion | 32 |
| Turnbull Talking | 32 |
| Rubic of Moggedon | 34 |
| Film Reviews, by Colin Greenland | 35 |
| Chain Mail, by Brian Creese, a new regular feature on postal gaming | 36 |
| Tavern Talk, by Pete Tamlyn | 38 |
| Letters, Clubs and Forthcoming Events | 38 |
| Fanzines | 40 |
| European Illuminati | 40 |
| Game Reviews, adventure games under the spotlight..... | 42 |
| The Sword of Alabron, Cartoon Adventure by Ian Williamson | 46 |
| Fair at Dragon Post, by Emmanuel | cover |



THE BEGINNERS' GUIDE



Carefully balanced on the window ledge, Tork drew out a piece of wire. Sliding it around the frame he lifted the latch and pulled the window open. He dropped silently into the room and signalled for Maeve to join him. She quickly scaled the wall and the two thieves grinned at each other. This was the place, and the merchant wouldn't be back for at least another hour.

Tork moved to the door and pressed his ear to the wood. He nodded to Maeve, satisfied that there was no movement in the hall. With a practiced eye she scanned the chest by the bed. Her attention was drawn by a tiny needle in the lock; she bent down and removed it with her pliers. She began to pick the lock. It did not open.

Cursing she stood up and signalled to Tork to try. The sound of footsteps was heard. Swiftly

they moved to either side of the door, their weapons ready. A key turned in the lock and a fat richly dressed figure holding a candle entered the room.

Maeve darted forward. Her left hand gagged the merchant while her dagger pricked his back. 'No noise or it's your last. Understand?' The merchant nodded, Maeve removed her hand and Tork closed the door. 'The keys to the chest if you value your life and no fast moves.'

Gingerly the merchant handed over a key. Maeve pushed him to the bed and securely bound his hands and feet with a piece of cord. A handkerchief pushed into his mouth ensured his silence.

Tork opened the chest to see clothes inside, quickly he threw them on the floor and searched for a secret panel....'

A taker by stealth and skulker in shadows, the thief is a common character in fantasy literature. Players of fantasy role-playing games can enjoy the thrill of carrying out daring robberies using their skills to relieve the wealthy of their riches.

The adventure took place during such a game. Sue is the referee who has created the setting and runs the game according to the rules. The players both assume the role of thief and act as though their characters are in the situations described by Sue. They both possess thieving skills which they use during the adventure. When they use a skill Sue rolls dice and compares the result to their skill scores to determine whether they succeed or not.

Anne (Maeve) and Alan (Tork) are attempting to rob a merchant's room while he is at a Guild meeting. Alan has successfully climbed the outside wall while Anne waits in the shadows below.

Alan — 'I'm trying to open the window. Can I reach the catch with any of my thief's tools?'

Sue rolls two dice and checks the score against Alan's **Open Locks** skill. He succeeds and opens the window.

THE ADVENTURES OF NIC NOVICE

SUE IS HELPING NIC CREATE CHARACTERS FOR HIS OTHER GAMES



... HOW DO I ROLL UP A COWBOY CHARACTER?



84

HERE AGAIN IT'S DIFFERENT. YOU USE PERCENTILE DICE (1-100) FOR YOUR GUNFIGHTING ABILITIES. THESE ARE YOUR SPEED, ACCURACY, BRAVERY, STRENGTH AND EXPERIENCE

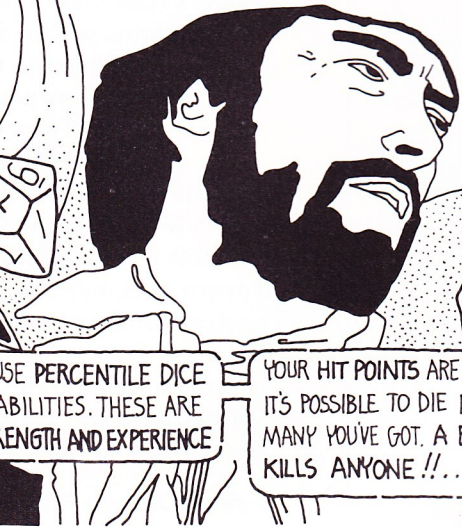

YOUR HIT POINTS ARE BASED ON YOUR STRENGTH BUT IT'S POSSIBLE TO DIE FROM ONE SHOT NO MATTER HOW MANY YOU'VE GOT. A BULLET THROUGH THE BRAIN KILLS ANYONE !!...

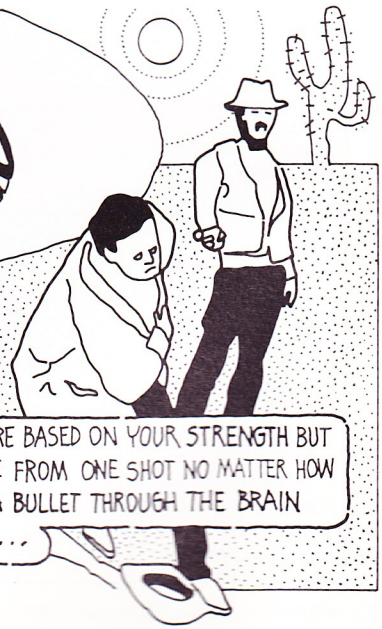

TO ROLE PLAYING GAMES



Alan — 'I'll signal to Anne that I've opened it. Then I'll try to **Move Silently** into the room.'

Sue rolls dice to see if Alan makes any noise and if Anne can climb the wall.

Sue — 'Anne, you climb the wall with no problem. Alan you see a richly furnished room with a four poster bed. A nightstand is next to the bed with a jug, a candle and an ashtray on it. On the other side of the bed is a wooden chest reinforced with metal bands. The floor is covered by rugs and furs. There is a door opposite the window and you notice that the area behind the door is lit.'

Anne — 'Good. Looks like we picked the right window. The door must lead to the hallway.'

Alan — 'I'll move to the door and listen.'

Sue rolls for Alan's attempt to **Hear Noise**. Knowing there is no-one in the hallway, she ignores the dice roll and tells Alan that he cannot hear anything.

Anne — 'I'll check the chest for traps.'

Sue rolls two dice and checks the result with Anne's **Find Traps** ability. She tells Anne that she sees a needle in the lock.

Anne — 'I'll try and remove it. If I succeed I'll pick the lock.'

Sue rolls the dice and is again successful, the poison needle is removed! The throw to **Open Locks** is, however, too high. Having failed, Anne cannot try again.

Sue — 'Alan, as you move away from the door you hear footsteps approaching and the jingling of keys.'

Anne — 'I'll hide behind the door and prepare to **Backstab** whoever comes in.'

Alan — 'I'll do the same on the other side.'

Sue — 'The door opens and a fat, richly dressed man enters the room, carrying a candle and muttering to himself.'

As the two thieves are trying to **Hide in Shadows** by the door, Sue rolls dice for each of them to determine whether the merchant notices them. He does not, and Sue informs Alan and Anne of this.

Anne — 'Is anyone with him?'

Sue — 'No-one follows him into the room and you can't hear anyone in the corridor.'

Anne — 'I'll **Move Silently** and take him by surprise. I place my hand over his

mouth and put my dagger against his back. I'm not trying to wound him, only let him know that I could do so easily.'

Sue rolls and tells Anne that she has no problems taking the merchant by surprise.

Anne — ' "No noise or it is your last." Does he understand?'

Sue — 'He nods and you notice beads of perspiration break out on his forehead.'

Alan — 'I'll check that the corridor is clear and close the door.'

Anne — 'I'll jab the merchant in the back and say "Give me the keys to the chest."'

Sue — 'He rummages around in his pouch and pulls out a key.'

Alan — 'I get the key and try it in the lock.'

Anne — 'I push him onto the bed and attempt to tie him up with a piece of cord from my pouch. Then I stuff my handkerchief into his mouth to gag him.'

Sue — 'He does not resist so you have no problem. Alan, you get the chest open and see that it is full of clothes.'

Jim Bambra

PART SIX — OTHER GAME SYSTEMS BY JIM BAMBRA AND PAUL RUIZ



BUSHIDO USES LESS LUCK IN CHARACTER GENERATION. YOU ROLL ON THE BIRTH TABLE FOR YOUR SOCIAL CLASS AND DECIDE WHAT PROFESSION YOU WANT TO FOLLOW.....

YOU HAVE 60 POINTS AVAILABLE, PLUS ANY BONUS POINTS FROM YOUR CHOSEN PROFESSION, TO ASSIGN BETWEEN YOUR STRENGTH, DEFTNESS, SPEED, HEALTH WIT AND WILL. CHARACTERS ARE BEST DESIGNED ACCORDING TO THEIR PROFESSION. A SHUGENDA (MAGIC USER) DOESN'T NEED TO BE STRONG BUT A SAMURAI DOES.....

ARE HIT POINTS WORKED OUT DIFFERENTLY AGAIN?

YES, HIT POINTS ARE THE CHARACTER'S HEALTH SCORE PLUS A DIE ROLL. IF YOU HAVE A HEALTH SCORE OF 24 AND YOU'RE A SAMURAI YOU HAVE 24 HIT POINTS PLUS 1 TO 10 HIT POINTS (1d10)

"Your mission, should you accept it:

LIBERATE WHAT'S LEFT OF MANKIND"

It's 150 years after the last nuclear devastation. You and your "player-friendly" team awake from suspended animation to find the world has become an alien environment. Mutant survivors terrorise the last remnants of civilisation.

The Morrow Project is a completely new and very playable role-playing system. The detailed combat rules incorporate features of most modern weapons systems, researched to ensure accuracy, leading to realistic situations which you must resolve.

And you're mankind's last hope to rebuild the world as you knew it.



*First complete scenario now available:
LIBERATION AT RIVERTON

THE MORROW PROJECT

For further information and for our latest FREE catalogue, send s.a.e. to:

FLYING BUFFALO

P.O. Box 100, Bath Street,
Walsall, W. Midlands.



Subscribe to **IMAGINE**TM magazine

12 Months Subscription Rates:

| | |
|---------------|--------------------------|
| UK & Ireland | £12 (post free delivery) |
| USA (AIR) | \$42 |
| USA (SURFACE) | \$30 |
| EUROPE (AIR) | £21 |
| Elsewhere | £25 |

Please make your cheque or postal order (no cash or international money orders accepted) payable to TSR (UK) Ltd. and send it to us at:

IMAGINE magazine (subscriptions),
The Mill, Rathmore Road,
CAMBRIDGE CB1 4AD.



BLOCK CAPITALS PLEASE

NAME

ADDRESS

POST CODE16

CLASSIFIED ADS

IMAGINETM magazine offers special rates to those interested in taking out classified advertisements. These cost just 10p per word or £3.00 per column centimetre (pre-payment required).

If you want to advertise in IMAGINE magazine write to:

IMAGINE magazine (classified)
The Mill, Rathmore Road,
CAMBRIDGE CB1 4AD.

J.R.M. SEDDON Please contact IMAGINE magazine with your address, so that we can reply to your enquiry.

HELP! War games fan in urgent need of back issues of **White Dwarf** no. 33 and **DRAGON** magazine nos. 61 and 63. Please reply to Box No. K12

SOUTHAMPTON'S Games Centre. All the latest games stocked from TSR, Games Workshop, Avalon Hill and many others. Also Citadel and Minifigs stocked.

PASTIMES II, East Street Centre, Southampton. Tel: 0703-21789.

OUTBOUND — a play-by-mail science fiction campaign game. Whilst a computer is used for data storage and random selections, the system is controlled by human referees. With personal control, greater emphasis can be placed both on innovative ideas and imaginative strategy of the players involved. For fast returns and attention to your ideas, **Outbound** is the route to take. SET UP & FIRST TURN £3.50, FURTHER TURNS £1.50 EACH. Send cheque or SAE for further details to: **OUTBOUND GAMES, 2 PARK WALK, FAREHAM, HANTS PO15 6NQ.**

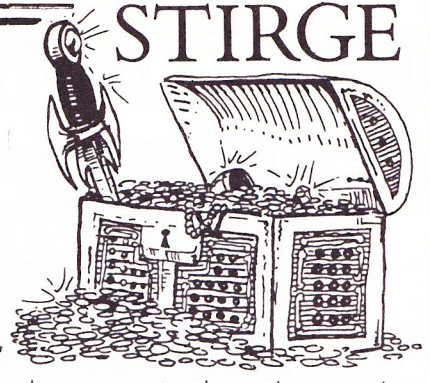

If I were to hand you a colourless liquid, that might make you very strong for five minutes, or might kill you instantly, would you drink it?

In the last few instalments of *Stirge Corner* I have been dealing with matters more particularly of interest to aspiring Dungeon Masters than to players, so I now intend to redress the balance a little, and provide some advice on successful play.

One thing I should make clear right at the start is that successful play does not have anything to do with going up levels faster than anyone else — far from it! The most successful characters you will ever play, those you will remember longest, will be those with the most distinctively developed personae. Characters with their own foibles and quirks will 'come alive' much more than those who are merely powerful statistics on paper. A cretinous character with a morbid fear of kobolds can be just as much fun to play as a souped-up Conan look-alike. It provides a greater challenge too.

Staying Alive

However, for a character to develop properly one thing is essential: survival! To flesh out the persona of your character, you need only exercise your imagination, but to keep him or her alive long enough to develop a history of adventures, you need a little common sense and a bit of gaming technique. Staying alive has its own advantages, but in the D&D[®] game it leads to the gaining of experience levels, making you more powerful and better equipped for winning treasure, and increasing your life expectancy.

Let me give you an example of some really bad play to demonstrate how characters can come to grief needlessly. I should start by saying that my campaign is usually reckoned by players to be one of the safest around — casualties are very low normally, provided players aren't silly. The following episode was a very rare instance of a total wipe-out.

Some first-level characters were making a foray into the first level of the dungeon. Going through a secret door near the entrance, they travelled down a long, wide corridor. Then the trouble started. The party split up, one part descending to level two, thus making one strong party into two weak ones. The hapless group on level two soon met a sticky end. The others continued to explore the passages of level one, eventually stumbling across the entrance to the goblin lair, guarded by a handful of sentries. What did the party

do? They stood around bickering loudly about whether to attack or not. While they did so, one of the sentries nipped off to fetch strong reinforcements, and soon it was the party that was being attacked. Despite being outnumbered, they fought on until all but one was dead. He managed to escape — the others could probably have done so too, had they even tried. Our lone warrior could have survived at least, if he had retraced his steps

longer you stay down, the more chance of meeting a wanderer that you can't handle in your weakened condition.

Moral number five: don't get into unnecessary fights. With the D&D game's combat system, almost any hand-to-hand combat will cost you hit points. Save them for when you really need them, either to win the big treasure or just to get out alive when cornered by a dangerous wanderer.

A page for the not-so-experienced adventurer

by Roger Musson

to the long corridor and exited via the secret door. Instead, he started to wander around, exploring rooms and eventually he found one with a monster in it of an unfamiliar type. With mind-bending stupidity, he rushed in to attack it single-handedly, and even persevered in hacking at it when he found he couldn't hit it (he needed a magic weapon). The lessons to be learned from all this follow as quickly as his demise did.

Musson's Morals

Moral number one: don't split the party unless you absolutely have to. It markedly increases the risk of fatalities.

Moral number two: don't go deeper than you can handle. Some players like to have character after character commit suicide in the deepest levels, hoping that one will eventually make off with a big unguarded treasure by a lucky fluke. This is bad play, and should be discouraged, by withholding experience level rises if need be.

Moral number three: plan beforehand. Don't have pow-wows down the dungeon if you can avoid it, and certainly not within earshot of monsters.

Moral number four: if the party becomes seriously depleted in strength, exit fast. Don't mess around opening doors you don't need to — there might be something nasty behind one of them. Also, the

I would add to the above, in conclusion, *don't take risks*. If you find a room with a battery of interesting-looking levers, my advice is to leave them alone! For every one that does something useful, there will be two that are electrified, or that plunge you into a pit full of green slime. It's just not worth it if you want to survive. I know players who go to such lengths that they will never drink any unknown potion lest it should be poison — and with good cause too. Forget the game for the moment; think of it like this. If I were to hand you, right now, a colourless liquid, and tell you that it might make you very strong, or perhaps very fast, for five minutes, or on the other hand, it might kill you instantly, would you drink it? No? Well, that's probably the way any sensible characters would think. Remember, there's no reason why they should want to die any more than you. Characters that don't take risks (apart from the calculated ones; adventuring, fighting, etc) may progress more slowly than those who press any button and turn any knob, but they tend to live a great deal longer.

 Roger Musson

Stirge Corner will continue to provide hints for players next month. If you find this feature useful in gaining an appreciation of role-playing games, remember that back issues of *IMAGINE*[™] magazine are available from TSR for £1.50.

NEW CAMPAIGN ADVENTURES FOR RUNEQUEST

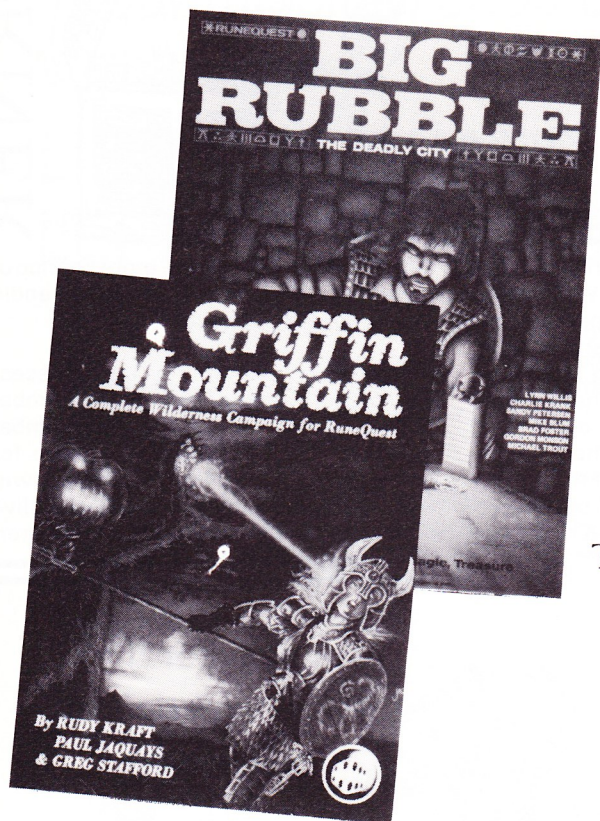

Griffin Mountain, the giant *Runequest* Campaign source-book, covers Balazar and the Elder Wilds — lands to the north of Prax. Now you can journey to these harsh barbarian lands and encounter over 400 NPCs and monsters with Games Workshop's UK edition of this popular *Runequest* supplement.

VISIT THE DEADLY CITY

The **Big Rubble** is Chaosium's latest scenario pack and companion to *Pavis: Threshold to Danger*. The Big Rubble is a ruined city outside the walls of Pavis, the home of outcasts, robbers and chaos creatures. Adventure within if you dare.

Griffin Mountain, UK edition, £9.95 and **The Big Rubble**, £14.95 are available from better games shops everywhere or direct from **Games Workshop Ltd.**, 27/29 Sunbeam Road, London NW10 6JP.

BEATTIES

TSR HOBBIES.
GAMES WORKSHOP.



You'll find all the winners, and much, much more — at your nearest Beatties store. Adventure into our magical halls!

A GREAT DEAL IN STORE FOR YOU

HOLBORN
High Holborn, London WC1V 6JS. 01 405 6285/8592

FINCHLEY
21/23 Ballards Lane, Finchley Central, London N31XP 01 349 2257

LEWISHAM
210 Lewisham High Street, London SE13 6JP 01 852 0449

SOUTHGATE mail order only
10 The Broadway, Southgate, London N14 6PN 01 886 4258

WOOD GREEN
104/106 High Road, Wood Green, London N22 6HE 01 888 0937

BIRMINGHAM
26 South Mall, Bham Shopping Centre, B2 4XD. 021 643 8604

BLACKPOOL
19 Hounds Hill Centre, Victoria Street, FY14HU 0253 26461

BRIGHTON
4/8 Dyke Road, BN1 3FE 0273 776626

BRISTOL
17/19 Penn Street, BS1 3AW 0272 20259

CARDIFF
Northgate House, Kingsway, CF14AD 0222 397645

CROYDON
135A North End, CR0 1TN 01 688 1585

KINGSTON
30/32 Eden Street, KT11EP 01 549 5464

LEEDS
16/18 King Charles Street, LS1 6LT 0532 456611

LIVERPOOL
36/37 Dawson Way, St Johns Centre, L11 1J 051 709 0799 70 The Parade, High Street, W01 2AW 0923 27563

MANCHESTER
4/6 Brown Street, off Market St, M2 1EE 061 834 0229

NEWCASTLE
43/47 Pilgrim Street, NE1 6DE 0632 324161

NOTTINGHAM
3 Mount Street, NG1 6JW 0602 411693

ROMFORD
7/11 High Street, RM1 1JU 0708 24283

SHEFFIELD
38 Pinstone Street, S12 2HN 0742 77864

SOUTHAMPTON
114 East Street, SO1 1HD 0703 24843

WATFORD

DRAGON BYTE

51a Queen Street,
Morley, Leeds 27



IN MORLEY TO SERVE
WEST YORKS

BOARD GAMES

* Adventure games for all ages including 'Dungeons & Dragons'.

HOME COMPUTERS & SOFTWARE

The famous ZX81 home computer for less than £50
Software games, education, adventures for ZX81, Spectrum, Vic, Atari etc.
Our range grows daily!

And now in Headingley
at Last Chance, 10 Ash Road,
Leeds 6 Tel: 744235.

A new 'split class'
for characters with
high strength
and dexterity

THE THIEF-ACROBAT

by Gary Gygax

This new official split-class for thieves marks a new point in the development of the AD&D™ game system. Rather than being a new character class available to players at the character creation stage, this class is more akin to choosing to change from one profession to another.

THE THIEF-ACROBAT

Any thief character with a minimum strength of 15 and a minimum dexterity of 16 may decide to forego normal thievery to become a specialist, a Thief-Acrobat. The thief then leaves off all practices which increase his or her manual dexterity and begins a regimen of physical exercise in order to build coordination, muscle tone and balance. This program of gymnastics precludes any further progress in the following skills:

| | |
|----------------------|----------------------------------|
| <i>pick pockets</i> | <i>find traps</i> |
| <i>open locks</i> | <i>remove traps</i> |
| <i>read language</i> | <i>read magic (never gained)</i> |

Skills ended at 5th level, while no longer improving, are not forgotten, so they remain at the level (5th) which the thief was when he or she began to specialise in acrobatics in conjunction with his or her profession.

Character abilities

Thief-acrobats with a strength of 16 or better and a dexterity of 16 or better add a 10% bonus to earned experience.

Strength Table III: Adjustments for Thief-Acrobat

Bonus for:

| Strength score | High jump | Standing long jump | Running long jump |
|----------------|-----------|--------------------|-------------------|
| 16 | - | - | 1/2' |
| 17 | 1/4' | 1/4' | 1' |
| 18 | 1/2' | 1/2' | 2' |

Note regarding Strength Table III: All bonuses are used to adjust the *Thief-Acrobat Function Table* detailed later. The adjustment for strength, plus racial adjustments, are added to the base chance for success or function maximums found there.

Dexterity Table III: Adjustments for Thief-Acrobat

Bonus for:

| Dex. score | Tightrope | | Pole vaulting | Tumbling: | | |
|------------|-----------|--------|---------------|-----------|---------|--|
| | walking | Attack | | Evasion | Falling | |
| 16 | 5% | - | 1% | 2% | - | |
| 17 | 10% | 5% | 2% | 3% | - | |
| 18 | 15% | 10% | 3% | 5% | 5' | |
| 19 | 20% | 15% | 4% | 8% | 10' | |

Note regarding Dexterity Table III: All bonuses are used to adjust the *Thief-Acrobat Function Table* detailed later. The dexterity bonuses here are added to the base chances for success or function maximums found there. Racial adjustments must also be made.



©1982, E. Gary Gygax.
All rights reserved

This article was first published in DRAGON® magazine, issue 69, January 1983, and is reproduced here by kind permission of that publication's editor.

Race of thief-acrobat characters

A member of any character race may opt to specialize as a thief-acrobat.

Character Classes Table II (Addition):

Armour & Weapons Permitted

| Class | Armour | Shield | Weapons/Oil/Poison |
|---------------|----------|----------|----------------------|
| Thief-Acrobat | as thief | as thief | as thief, plus staff |

THIEF-ACROBAT TABLE I

| Experience points | Level | Level title |
|-------------------|-------|--------------------------------------|
| 20,001 — 45,000 | 6 | Burglar-Acrobat |
| 45,001 — 75,000 | 7 | Second-Storey Thief |
| 75,001 — 125,000 | 8 | Cat Burglar |
| 125,001 — 180,000 | 9 | Master Cat Burglar |
| 180,001 — 250,000 | 10 | Thief-Acrobat |
| 250,001 — 500,000 | 11 | Master Thief-Acrobat |
| 500,001 — 750,000 | 12 | Master Thief-Acrobat (12th level) |

250,000 experience points for every level beyond the 12th.

The Thief Acrobat

Upon gaining sufficient experience points to achieve 6th level ability as a thief, the character desiring to specialize as a thief-acrobat must seek out a character already in this profession who can provide training. The established thief-acrobat must be of at

least 10th level. It will require 6 full weeks of training to learn the basic skills needed to begin active practice of the special profession of thief-acrobat. Except as noted, the specialization procedure is otherwise exactly the same as for a normal thief.

The primary functions of a thief-acrobat are: 1) *tightrope walking*; 2) *pole vaulting*; 3) *jumping*; and 4) *tumbling*. In addition to these functions, the thief-acrobat retains the abilities to *move silently*, *hide in shadows*, *hear noise* and *read languages* acquired through to the 5th level of the standard thief profession. Although the ability to read magical writings is never gained, the ability to *climb walls* is still increased according to experience level.

Tightrope walking assumes that the character will use this means to cross from place to place. The skill allows ascent of a rope or beam at up to a 45° angle or descent at a slightly steeper angle, all while upright and with hands free (in general). This is achieved by balance, muscle coordination, and superb reflexes.

Pole vaulting includes any jumping which employs a leverage device to assist the individual in gaining height from momentum; ie a teeter board or springboard might serve as well or better than a pole in some cases. It will help to get quickly to the top of or over obstacles. It requires strength, dexterity and practice to improve.

Jumping includes all sorts of unassisted leaps — high jumping and long jumps (both from a standing and running start) being important here. The skill requires coordinated strength and continual practice.

Tumbling assumes all sorts of gymnastic skills — tumbles, rolls, jumps, handstands and so on. These routines are then used in attack, defensive evasion and in jumping/falling.

THIEF-ACROBAT FUNCTION TABLE (plus racial adjustments)

| Character level | Tightrope walking | Pole vaulting | High jumping | Long jumping: | | Attack | Tumbling: | |
|-----------------|-------------------|---------------|--------------|---------------|---------|--------|-----------|---------|
| | | | | Standing | Running | | Evasion | Falling |
| 6 | 75% | 9' | 4' | 4' | 8' | 6% | 10% | 25%/10' |
| 7 | 80% | 9 1/2' | 4 1/4' | 4 1/2' | 8 1/2' | 7% | 15% | 50%/10' |
| 8 | 85% | 10' | 4 1/2' | 5' | 9' | 8% | 20% | 75%/10' |
| 9 | 90% | 10 1/2' | 4 3/4' | 5 1/2' | 9 1/2' | 9% | 25% | 25%/20' |
| 10 | 95% | 11' | 5' | 6' | 10' | 10% | 30% | 50%/20' |
| 11 | 100% | 11 1/2' | 5 1/4' | 6 1/2' | 10 1/2' | 11% | 35% | 75%/20' |
| 12 | 100% | 12' | 5 1/2' | 7' | 11' | 12% | 40% | 25%/30' |
| 13 | 100% | 12 1/2' | 5 3/4' | 7 1/2' | 12' | 13% | 45% | 50%/30' |
| 14 | 100% ¹ | 13' | 6 1/4' | 8' | 13' | 14% | 50% | 75%/30' |
| 15 | 100% ¹ | 13 1/2' | 6 1/2' | 8 1/2' | 14' | 15% | 52% | 20%/40' |
| 16 | 100% ² | 14' | 7' | 9' | 15' | 16% | 54% | 40%/40' |
| 17 | 100% ² | 14 1/2' | 7 1/2' | 9 1/2' | 16' | 17% | 56% | 60%/40' |
| 18 | 100% ³ | 15' | 8' | 10' | 17' | 18% | 58% | 80%/40' |
| 19 | 100% ³ | 15 1/2' | 8 1/2' | 10 1/2' | 18' | 19% | 60% | 20%/50' |
| 20 | 100% ⁴ | 16' | 9' | 11' | 19' | 20% | 60% | 40%/50' |
| 21 | 100% ⁴ | 16 1/2' | 9' | 11' | 20' | 20% | 60% | 60%/50' |
| 22 | 100% ⁵ | 17' | 9' | 11' | 21' | 20% | 60% | 80%/50' |
| 23 | 100% ⁵ | 17 1/2' | 9' | 11' | 21' | 20% | 60% | 20%/60' |

Racial adjustments:

| | | | | | | | | |
|----------|------|-----|-----|---------|-----|------|------|------|
| Dwarf | -5% | -2' | -1' | -2' | -3' | +10% | +5% | — |
| Elf | +10% | — | — | — | -1' | — | +5% | +5% |
| Gnome | — | -2' | -1' | -1 1/2' | -4' | +5% | +5% | — |
| Half-elf | +5% | — | — | — | — | +5% | — | — |
| Halfling | — | -2' | -1' | -1 1/2' | -4' | +5% | +10% | +5% |
| Half-orc | — | — | — | — | — | — | — | +10% |

¹ — Includes the ability to carry up to 1,000gp weight/encumbrance in addition to normal load, *or* handle a moderate wind with no penalty to the chance of success.

² — Includes the ability to carry 1,000gp weight/encumbrance in a moderate wind, *or* carry up to 2,000gp weight/encumbrance, *or* handle a strong wind.

³ — Includes the ability to carry up to 2,000gp weight/encumbrance in a moderate wind, *or* 1,000gp weight/encumbrance in a strong wind.

⁴ — Includes the ability to bear up to 3,000gp weight/encumbrance, *or* as in ³ above.

⁵ — Includes the ability to carry up to 2,000gp weight/encumbrance in a strong wind, *or* bear up to 3,000gp weight/encumbrance in a moderate wind, *or* bear up to a maximum of 4,000gp weight/encumbrance.

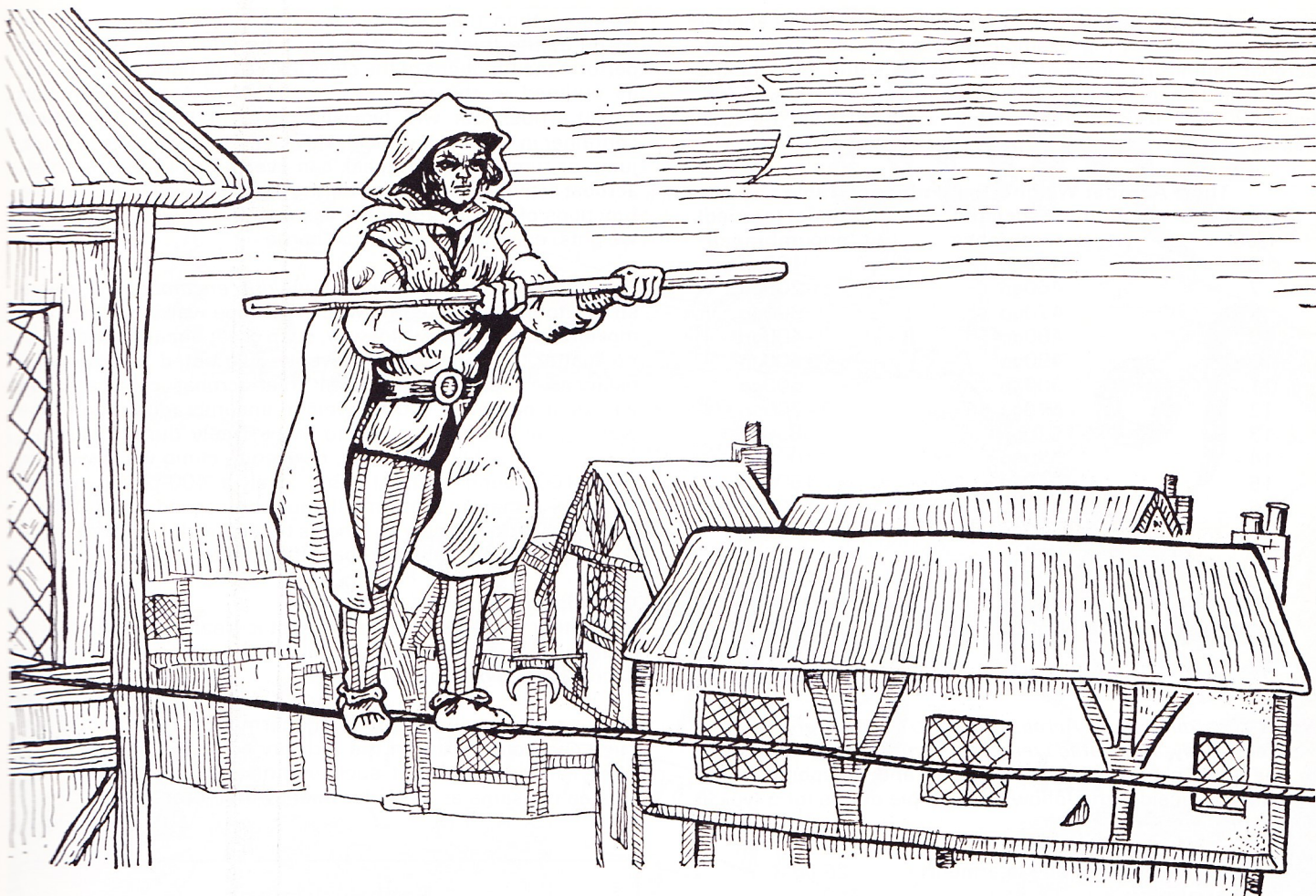

Note regarding Thief-Acrobat Function Table: Where applicable, roll percentile dice to determine success or failure of an attempt. Scores must not be greater than the percentage generated in order to be successful.

Tightrope walking assumes that the character will be travelling no more than 60' distance. Movement rate is 60'/round. If the distance is greater than 60', then additional checks must be made. Moderate winds decrease chance of success by 10%, strong winds by 20%. In strong, gusty conditions there is *always* a 5% chance of failure. In non-windy conditions a balance pole increases the chance of success by 10%. Failure to perform successfully means that the character falls to the area below, taking damage accordingly.

Pole vaulting requires at least a 30' running start and a pole of at least 4' greater height than the vaulter. The pole is dropped when the vault occurs. The vaulter can land feet-first atop a surface of half or less height than the maximum height of the pole vault if so desired, assuming such a surface exists. Otherwise, the vaulter lands, tumble-rolls, and is upright in 1 segment.

High jumping requires at least a 20' running start. The high jumper clears the obstacle in a near-horizontal position but lands feet-first. If some elevated step, or a series of such steps, enables the character to maintain rapid motion, it is possible to high-jump from such an elevated position just as if doing so normally. Alternatively, the jumper can opt to land atop some higher surface. This surface must be no more than 4' above the level from which the jump is made, or 2' under the maximum height for normal high-jumping, whichever is the greater. In either case, the thief-acrobat lands upright in 1 segment.

Long jumping is self-explanatory. A jump of any sort requires only a single segment to accomplish. A running long jump requires an approach of at least 20'. In standing jumps, the thief-acrobat can leap forward up to the maximum distance, or backward up to half the maximum distance, in order to attack or avoid being in attack range, if this is deemed possible by the DM.

All jumps assume the character will land upright. If the character wishes to leap in an extended position, 2' of additional distance can be gained, but the character will then land prone and require two full segments to stand. A 3' extension can be attempted, but this has a 25% chance of failure and a 3-segment period of recovery; a 4' extension has a 50% chance of failure and a 4-segment recovery and a 5' extension has a 75% chance of failure and a 5-segment recovery period.

Tumbling routines have the following benefits. *Attack* adds the indicated percentage to the character's chance for success in hand-to-hand combat involving grappling, pummeling etc. *Evasion* enables the character to opt to evade direct attacks — just as magical resistance would work with respect to magical attack forms directed at the individual (or a relatively small area, such as a few square feet, from which the thief-acrobat could easily escape), or from melee combat — in the case where the thief-acrobat has the initiative, but only in this case. In any event, the chance of success cannot exceed a base of 60%, adjusted for dexterity and/or race. Evasion routines of any sort require 1 segment maximum to perform. *Falling* percentage indicates the chance for the thief-acrobat to take no damage from a fall of the indicated distance. Thus, at 6th level there is a 25% chance that the character will take no damage from a 10' fall. If damage is taken, the converse of the percentage to avoid damage is used to find maximum damage. Again in the case of a 6th level thief-acrobat falling 10' and taking damage, only 75% of normal (1d6) damage, rounded down, is taken. Note that at 9th level it is not possible for a thief-acrobat to take damage from a 10' fall, and there is only a 25% probability of damage from a 20' fall. Again, only damage from the second portion of the fall's distance would be considered if damage was indicated. Example: a 23rd level thief-acrobat is knocked off a tightrope and falls 60' to the rocks below. No damage would be sustained if the fall were 50' or less, but in a 60' fall the character's body reaches a high velocity, such that unless 20% or lower is scored by the character on a falling roll, he or she will take 80% of the usual amount of damage for a 60' fall, so it is 80% likely that 80% of 6d6 damage would be taken. Falls of a distance longer than the 'safe' distance for a particular thief-acrobat add their normal

increment of damage dice, regardless of elimination of shorter distances. Thus, in the example above, the 23rd level thief-acrobat falling 70' instead of 60' would suffer 80% of the maximum damage for a 60' fall (80% of 6d6), plus 100% of 7d6. For an 80' fall, 100% of another 8d6 would be added; the total damage therefore would be 15d6 plus 80% of 6d6.

Thief-Acrobat Weight/Encumbrance Table

| Experience level | Body-associated wt/encumbrance | Additional (carried) wt/encumbrance |
|------------------|--------------------------------|-------------------------------------|
| 6 | 450gp | 100gp |
| 7 | 460gp | 200gp |
| 8 | 470gp | 300gp |
| 9 | 480gp | 400gp |
| 10 | 490gp | 500gp |
| 11 | 500gp | 600gp |
| 12 | 510gp | 700gp |
| 13 | 520gp | 850gp |
| 14 | 530gp | 1000gp |
| 15 | 540gp | 1500gp |
| 16 | 550gp | 2000gp |
| 17 | 570gp | 2250gp |
| 18 | 600gp | 2500gp |
| 19 | 625gp | 2750gp |
| 20 | 650gp | 3000gp |
| 21 | 660gp | 3500gp |
| 22 | 670gp | 4000gp |
| 23 | 700gp | 4000gp |

Notes regarding Thief-Acrobat Weight/Encumbrance Table: The term *Body-associated weight/encumbrance* refers strictly to the clothing, accessories, armour and weapons of the character. Consider the following example of this for a typical character:

| | |
|---|--------------------------------------|
| Clothing (partial only due to armour) | 20 gp w/e |
| Leather armour | 150 |
| Boots, soft | 30 |
| Belt | 3 |
| Belt pouch, large | 10 |
| Belt pouch, small | 5 |
| Cloak, hooded | 25 |
| Dagger and scabbard | 10 |
| Short sword and scabbard | 35 |
| TOTAL | 288 gp w/e |
| Balance for additional equipment and/or loot: | 162 (minimum) |
| GRAND TOTAL | 450gp (maximum for 6th level) |

No more than the indicated weights/encumbrances can be borne by the thief-acrobat at any time and when wanting to perform the functions of the class (except for tightrope walking, as outlined in the footnotes to the Thief-Acrobat Function Table). Thus, loot will typically be carried in a hand-held container in order to be quickly rid of it and thus be able to vault, jump or tumble. No backpack can ever be worn during thief-acrobat activities, other than during tightrope walking. Climbing functions of the thief-acrobat assume that only the stipulated weights/encumbrances will be borne.

The term *Additional (carried) weight/encumbrance* refers strictly to the weight borne when tightrope walking. Since this movement is very slow anyway, such great encumbrance is of no matter, as long as it is evenly distributed and properly balanced. Thus, a 14th level thief-acrobat can carry an additional burden of 1000gp weight/encumbrance in tightrope walking, but cannot expect to move freely during vaulting, jumping or tumbling routines, or even to climb walls with an extra 100-pound load. At 22nd level, a 400-pound person (perhaps a man in plate mail) could be carried on the thief-acrobat's back, but only so long as that individual did not move so as to throw the thief-acrobat off balance.

Other information

In all other respects the thief-acrobat is treated as a thief. This includes *followers*, *abilities*, *setting traps* (at 5th level of ability, of course) and *gaining experience*.

Thief-acrobats will be part of the normal thieves' guild if any such characters exist in the territory controlled by the guild. They can be leaders of such organisations, since they are treated the same as a regular thief by their brethren.

Gary Gygax

Falling damage

A revision of the method for determining falling damage appeared in the same issue of DRAGON™ magazine, as follows. 'The correct procedure for determining falling damage in the AD&D game system is to roll 1d6 per 10' fallen, *cumulative*. Since a falling body accelerates quickly, the damage mounts geometrically: 2d6 for the second 10 feet fallen, 3d6 for the third 10 feet, etc. The maximum of 20d6 is therefore reached after a fall of approximately 60 feet for most characters. A thief-acrobat can often fall further distances, but the same 20d6 maximum should be applied.'

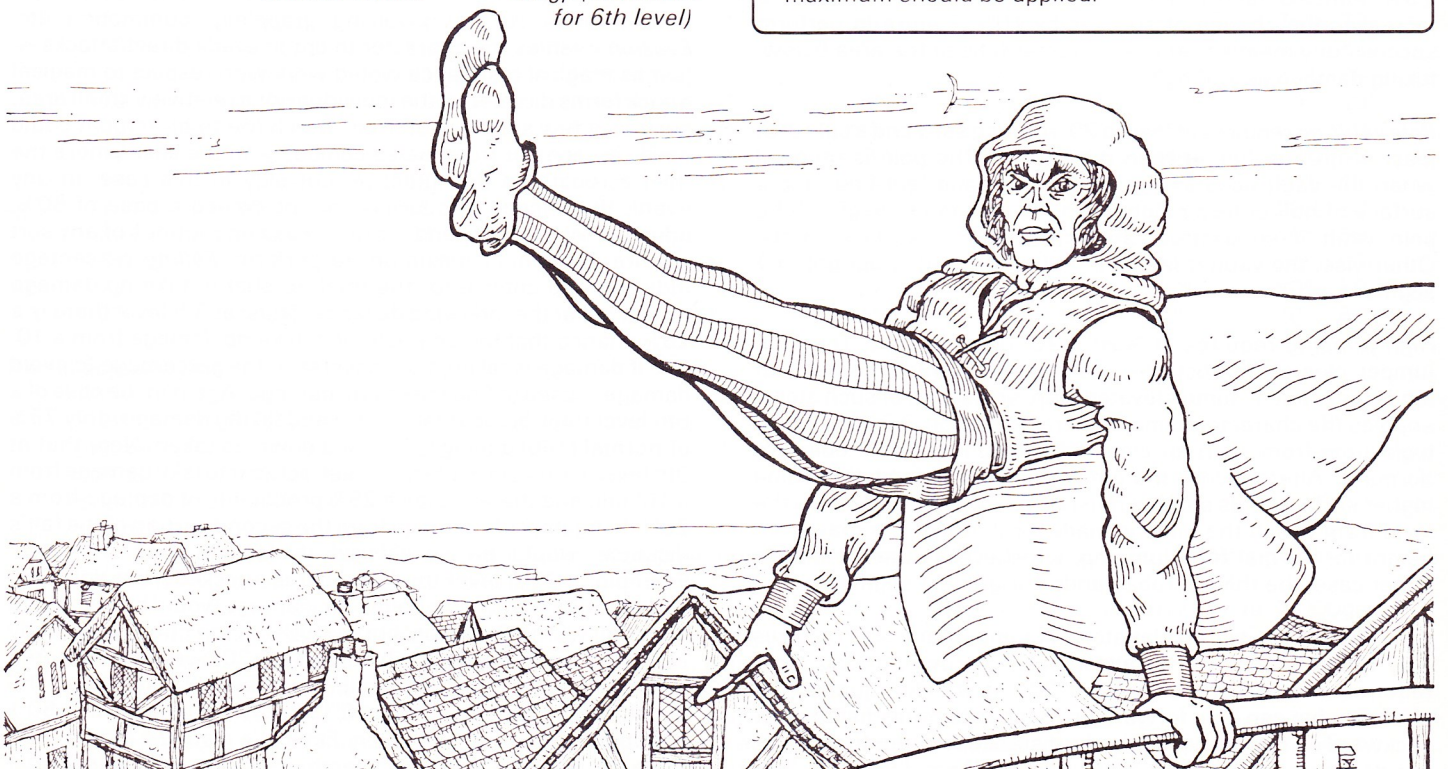

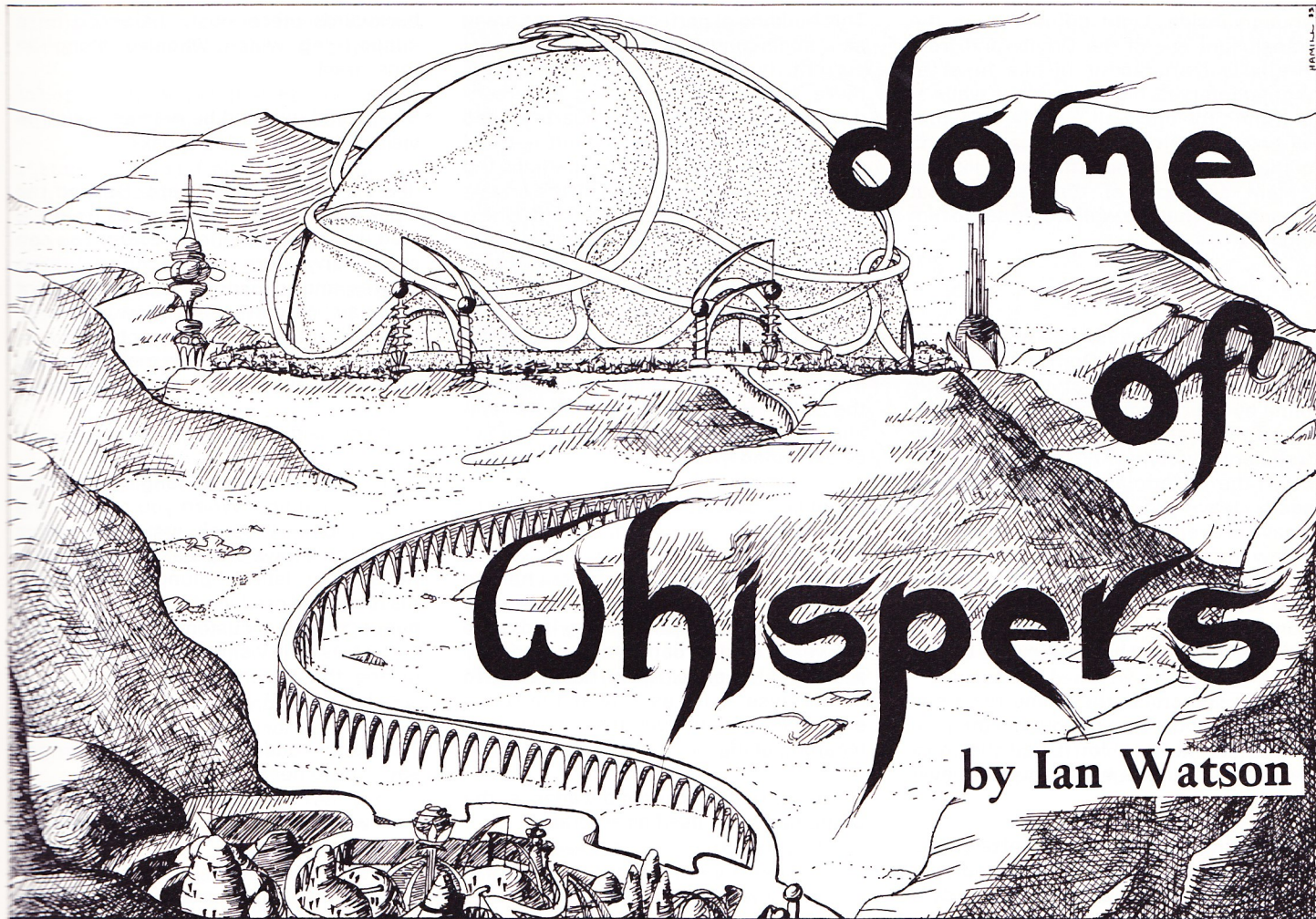

Welcome to the Dome of Whispers, star-stranger. I am Istinbat. Please let me assure myself that you carry no recording devices or other instruments. The visitor to the Dome of Whispers may bring only himself, or herself....

'You may leave your wrist computer here. No-one will touch it.'

The burly man shed his bracelet, and Istinbat placed it on a shelf. The shelf was otherwise empty; there were no other visitors yet. Perhaps there would be no others.

Istinbat looked out from the doorway briefly, imagining the splendid view of the Dome, golden in the morning sun, that this stranger must have enjoyed as he approached up the road from Wakil City. The Dome rose three hundred metres at its zenith, and was a full kilometre around its base. The area immediately surrounding it was paved in turquoise marble, well worn by the scuff of countless feet down the millennia — though this was one of those centuries when the number of feet was more easily countable. Just off the marble stood a line of hutches, where vendors — poor brown folk with flashing teeth — were only just now putting up their shutters, to hawk their holopictures, spiced buns, wine flasks, fresh fruit, bowls of spiced goat's meat stew. Mainly they supplied the guardians of the Dome with food and drink; tourists were only a

sideline. A stall concession at the Dome was a rare prize for a poor man; and only to a poor man would it go by tradition. The stall holders would bring the food and drink over when a bell tolled. Istinbat himself had not stepped outside of the doorway for perhaps a year.

The burly man fidgeted.

With a shrug, Istinbat turned from the doorway to the outside world. He pulled a cord which would summon another guardian from the catacomb quarters underneath the Dome. Twitching a taper alight, he preceded the visitor down the flight of steps into the long downward tunnel leading to below the mid-point of the Dome.

Istinbat was a tall thin man, with a long nose, thin pursed lips and eyes of a startling violet hue: the face of a sucking insect. His head was shorn, and he had a creamy skin, much lighter than the norm on this world, blanched by long attendance in the Dome. He held the taper high, and thus they proceeded down the tunnel in a cocoon of light.

'Will you be staying in the Dome with me?' asked the visitor idly enough, though the answer obviously mattered to him intensely.

'A guardian has to stay — though not intrude. I shall station myself a fair way off. You may take as long as you like. All day, till dusk. I shall not get bored, with all

the voices speaking to me. I have hardly heard the same one twice, in all my years since I was a boy.'

'Hmm,' said the visitor. Obviously the answer pleased him. What private message was he hoping to hear — or to leave — in the Dome? Yet this was no concern of Istinbat's, except in so far as it had been a very long time since anyone had come to the Dome from another world with a specific purpose beyond simple curiosity.

As they walked, a second cocoon of light approached them. A similar tall robed figure — the woman Tasamma — glided past, with a nod to Istinbat, as routinely as an ascending funicular railway cab passes a descending one midway.

The tunnel opened into a large circular chamber, with several brass-bound doors beyond which were the labyrinths of living quarters, and burial places. Once, there had been a hundred guardians. Now there were scarcely twenty.

A well-worn spiral stone stairway led up into the Dome itself. Istinbat held the taper well clear of his body to illuminate the steps; there were a hundred of these.

He noticed that the visitor did not puff or wheeze as he climbed.

As the man stepped up into the centre of the great bare floor of the Dome, Istinbat twitched out the taper. It was luminous

enough inside. Light diffused from the translucent eye of the Dome, and from similarly translucent blocks inset at regular intervals high around the walls — or rather, the one wall. Faintly, from that all-encompassing wall, the massed echo of the whispers came to their ears like the distant sussurus of the sea. Istinbat wondered what the wall would say to him today....

In the southern hemisphere of the planet Suf stood this famous Dome of Whispers: famous in the sense that it was the only thing by which most star people remembered the planet Suf these days. Much turbulent history had flowed through Suf down the millennia — and ebbed away again, leaving Suf to its own private weave of events, of which nowadays only a few threads remained. Yet Suf still ticked on, even though the clock (as they said locally) had no hands; and the old Dome endured, though comparatively little visited except by those native to Suf.

While it still stood, the Dome remained one of the most remarkable buildings in all the star worlds; for it had the most peculiar acoustics of any building ever raised.

Whispering galleries existed elsewhere: places where you spoke softly and your companion heard you clearly hundreds of metres away around the building. But in the Dome of Whispers, alone, no utterance was ever lost. Whatever was spoken there continued on around the Dome forever, quietly, undiminished.

This building of perfect proportions acted as a superconductor — not of electrical current, but of sound waves. Perhaps there really was something superconductive about the unique quartz-veined marble of which it was built — and something piezoelectric too; perhaps the slight compression caused by the impact of sound waves set up a current which stored and reproduced the spoken word again and again around the Dome. Perhaps. The guardians of the Dome had never permitted anyone to take the smallest flake of a sample away nor bring any kind of mechanical or electronic instrument into the Dome. It was all that the Sufish had, this Dome. Better that it should remain a prodigy, a marvel, than be explained away.

For millennia past the people of Suf, both common and uncommon, and intermittently the people of other star worlds (generally uncommon) had come here to whisper the secret of their lives or a confession or a prophecy. They had come to swear a binding oath or a love pledge or a vow of revenge. They had come to immortalise — for as long as the Dome endured — their own insight into the meaning of life.

During periods of Sufish decadence, the Dome had been used as an oracle....

Around the perimeter of the floor stood various mobile ladders resembling pieces of ancient siege-gear. Their wheels rested on a track running right around the circuit of the wall. These ladder-towers leaned

backwards precariously, balanced on a support leg which wheeled along an inner track.

'I expected it would be noisier,' said the visitor. 'Uhshould I speak?'

'It's all right to speak here. Beyond the black marble line, three metres from the wall, is where the effect occurs. You can speak anywhere within those three metres, and be recorded at that very point in the air. We don't really know how large the capacity is — certainly not infinite — therefore each visitor may make only one statement, and then he must withdraw.'

'But you said that I could....'

'You may *listen* for as long as you like. With sealed lips. When you remove the seal, you may speak just once. Most people only have one real thing that they need to say.' Istinbat plunged a hand into his robes and produced a strip of adhesive bandage. 'I am accustomed to silence, but I must ask all visitors to seal their lips during the Listening, till they wish to speak.'

The visitor nodded. 'Only one real thing to sayor to hear — it's quite true.'

And what is your real thing? wondered Istinbat.

The visitor stared around the Dome. Twelve metres above the floor was a continuous inscription cut in an angular script; it ran around the whole circuit of the wall. The inscription was repeated exactly in the black marble of the boundary line. The visitor pointed at it, sweeping his finger along.

'It is the whole of the ancient poem known as the *Ruby Yat*,' said Istinbat, 'in the old script of Suf. A poem on the theme of mutability and eternity. Very few people can read the old Sufish script these days. Lovers sometimes match up the angles of the letters, above and below on the floor, as a way of marking where they pledged their love. They copy down the piece of text, without understanding it. Even so, it might take them quite some time to find the exact point where they spoke, and the exact angle of their lips.'

'But can you read it?'

'Oh yes, that is something else that we guard: a knowledge of the sounds of those letters.'

'Will you read some of it for me? Please. I will pay you generously.'

'Why should I need money? But I will read it, if you wish. Come, we will walk to the beginning.'

'No, I already know the *Ruby Yat* by heart. I am looking for one particular passage.'

'So, a friend has been here, perhaps? It's unusual, to know the *Ruby Yat* by heart.'

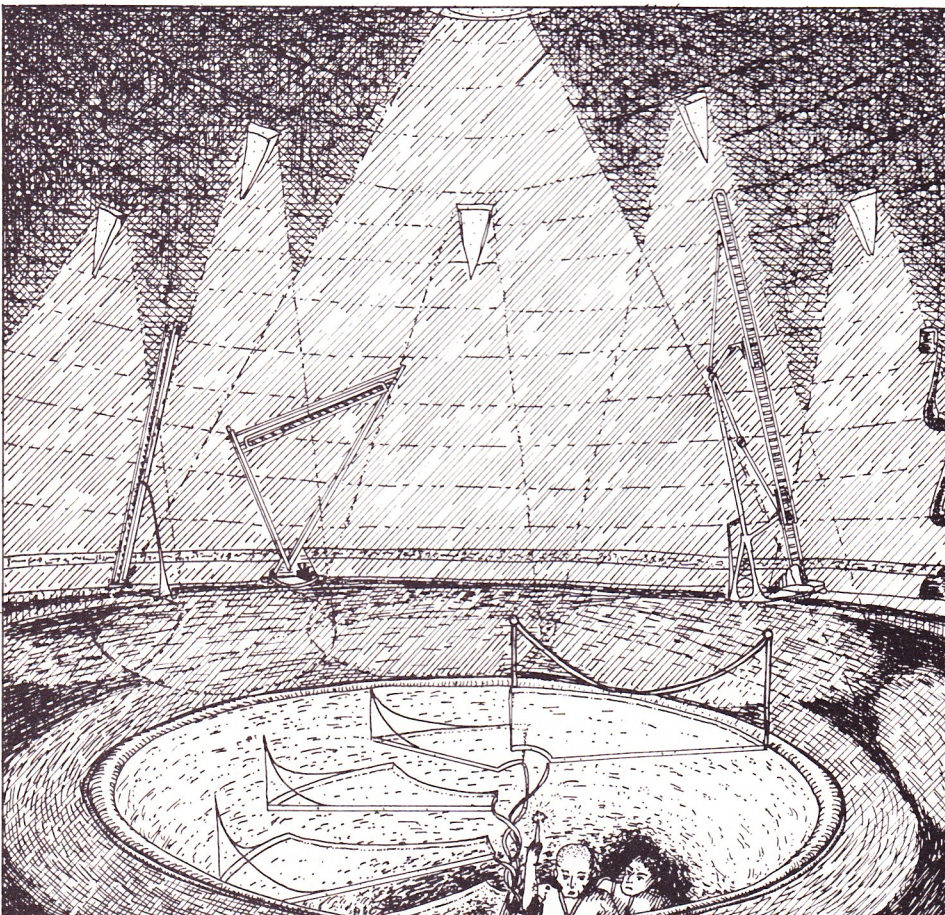

'It's handed downin my family. But this is the only example of the old script left.'

What family would that be? wondered Istinbat. Was this man a scholar?

Historians from off-planet had, from time to time, eavesdropped on one voice, then another, then the one aftersifting the equivalent of a ton of ordinary potsherds to find, by chance, one golden brooch or King's insignia, one historic confession or vow. They soon gave up, their heads full of peasant love-words, verbal graffiti, portentous statements by the totally forgotten.

'What passage?' he asked.

And the visitor recited:

*"Of my Base Metal may be filed a Key
That shall unlock the Door to
Paradise."*

But that's wrong,' said Istinbat. 'It should be:

*"Of my Base Metal may be filed a Key
That shall unlock the Door he
howls without."*

The man's face darkened. 'Yes, yes, of course it is. How stupid of me.'

'But if you memorise the whole poem, in your family....? I suppose changes creep in. Corruptions of the text.'

'Yes, yes, they creep in.'

'But you knew you had made a mistake.' Istinbat thought briefly. 'Where the text diverges, is that where you expect to find the message waiting for you?'

'Just show me where those words are, will you?'

'I am doing you a favour, star-stranger....'

'And you don't want money. What do you want?'

'Why, I am curious. Events do not happen on Suf these days. I have a feeling that this is an event.' Istinbat felt a curious sensation, of *power*. It was an unusual sensation, and not one that he particularly cared for. This burly visitor was, perhaps, accustomed to poweror else he remembered power. Here, however, amidst the tide of voices he was powerless.

'But aren't you vowed to silence.... Istinbat?' The visitor had named him, to forge a relationship.

'Yes. But at the same time a guardian feels curiosity about the myriads of voices he hears.'

'If only he could identify one of them, is that it?'

Istinbat chuckled dryly. 'Most people identify themselves. Right here is there

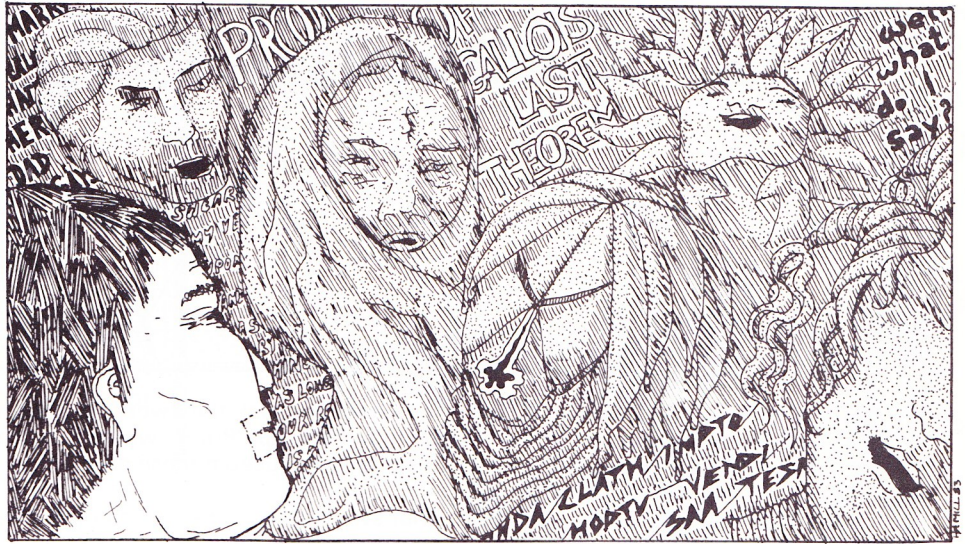

immortality. I will show you. Seal your lips. You may reflect upon the phenomenon of the Needle and the Haystack.'

'But you said you would stand a fair way off.'

'And now you have involved me.'

Once across the black marble strip, it was like dialling through the air-bands of an enormous radio; catching a word here, a phrase there, half a sentence — switched away by the least movement on their part. Here was the archeological deep litter of thousands of years, compressed into three metres of whispering air, every millimetre of which clamoured for attention, begging to be heard.

Yet unlike an archeological site, here there was no depth yardstick of time. So here was a plea out of the deeps of time.... perhaps. Here, next to it, was a promise from last yearperhaps again. There was no discernible difference in the signal strength. It did not matter whether the original speakers had cried out loudly or murmured most quietly. Each whisper had the same strength as the next. Nor did they overlap, however crowded together they were. No-one talked anyone else down. Each whisper was equal.

The visitor moved as if he was moving through treacle, though actually there was no resistance except for the drag of fascination.

He moved his head in tiny quantum jumps from one whisper to the next. Ah yes, one heard with the left ear or the right ear.... but never with both at once. One heard *inside* the ear.

'Orelida, thee I love forever....' Dust.

'....yaum el-nnushur....' Unknowable.

'....anda klath impto hoptu vendi saa....' What language?

An alien hissing and croaking, never from a human throat....

'I swear my vengeance upon Satpat and all his heirs, by all of mine, for as long as our revenge is renewed in this iota of ever-air....' How long did that blood feud last for? Or had it merely just begun?

A nervous giggle: *'Well, what do I say?'*

A crisp voice: *'This is Sully Hoberman from Alpha C in the Suf year 5079. The proof of Galois' last theorem, which I have now found, is as follows....'* Was Sully Hoberman right or wrong? Who knew? Who remembered?

A primping voice: *'I, Marquis Enderby, will now recite my prize-winning ode which placed first in the Concourse of Poetry at Middlestar....'*

'I'll marry Lala whatever her Dad says....'

And on. And on. An infinity of voices.

Well, not an infinity; but very many.

Istinbat let the stranger listen for ten or fifteen minutes, then laid a hand on his arm and nodded him back across the black marble strip. Gently, he detached the adhesive strip from the man's lips.

'Now will you satisfy my curiosity, star-stranger?'

The visitor glanced around the Dome again, confirming that it was still empty but for the two of them. He flexed his hands. Strong hands they were.

'I suppose I shall have to!'

And this the stranger proceeded to do; and it began to dawn on Istinbat that he had put himself in danger of his life. Surely no-one would attempt to murder a

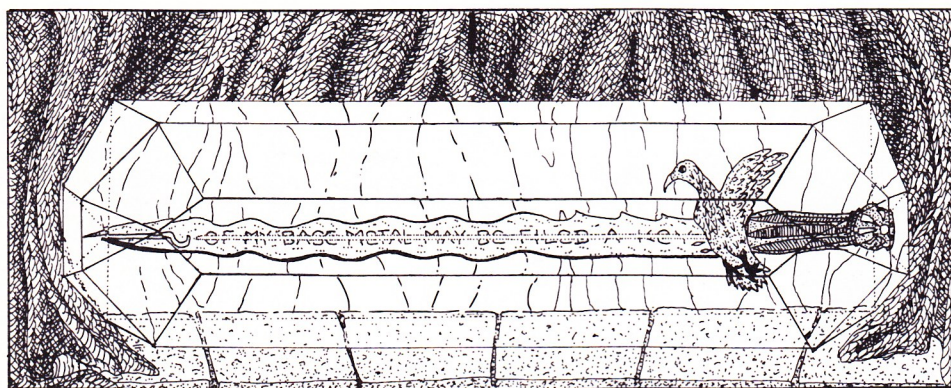

guardian in the very Dome itself? Still, as the man spoke, Istinbat measured himself against him.... unable, even so, to bring himself to call a halt to the stranger's words. For this was the Event, and it seemed as though Istinbat had been waiting out his whole life to connect with this moment.... of History.

The Empire of Tajalam, at its height a thousand years earlier, spanned seven worlds in the Praesepe Cluster, that mass of stars five hundred light years from old Earth for which the fanciful old Earth-Chinese name was 'the exhalation of piled-up corpses.' Regarded with an unromantic eye, Tajalam's Empire seemed amply to merit the Chinese description. Yet, despite his barbarities, Tajalam had been a remarkable character who persisted in sending out expedition after expedition into deepest space long after all other exploration and pioneering had slowed to a snail's pace.

He was searching for no less than Paradise. A Paradise planet, which he believed must exist somewhere among the millions of suns.

Perhaps it had to exist, simply to counter-balance the hell of Praesepe.

And Paradise had been found.... somewhere.... by the last and smallest expedition. No doubt it spoke volumes for the loyalty that Tajalam inspired, or the terror he induced, that the expedition came back at all to tell him. Probably the former, since by then his Empire was crashing about his head, and he was on the run. Apparently he ran by way of Suf, before eventually committing suicide with his ritual ruler's sword in the city of Qalb on Usul. From some personal quirk — which those of his descendants who survived the pursuing wolves had enshrined as a tradition — Tajalam had adopted the *Ruby Yat* as the basis of his private battle-code and cipher system.

It was a strict part of Praesepe culture that a dead ruler's sword should be preserved in public for ever more. In Tajalam's case, his enemies might have felt like melting it down — but not when it was stained with his own blood. That final act of his had sealed the sword into the stone of history forever. Thus his victor-

ious enemies took the sword back with them to Praesepe Prime, where it lay in their central museum these days.

That sword had an inscription on it: the words which had pierced his heart....

'We didn't find *that* out, Istinbat.... not for nine hundred years. We were scattered to the stars, as far from Praesepe as possible, living under new names, often living in poverty.'

'We?'

'The direct line of Tajalam. It's *unusual* for a ritual ruler's sword to have an inscription on it, you see. We believe the words were inscribed shortly before he killed himself, and some time after he passed through Suf. They were a message to his heirs, which his immediate heirs never received.'

'They were the key to the paradise planet?'

'Exactly. And it's here. The celestial coordinates to Paradise are here. Now I've slaked your thirsty curiosity, perhaps you would tell me,' the visitor gestured impatiently, '*approximately* where?'

'I will have to remain alive afterwards,' said Istinbat, hoping that he did not sound as though he was begging for his life. Though how could he ensure that he remained alive?

No doubt, in the last thousand years, Tajalam's line had become more settled in their ways, less inclined to produce exhalations of piled-up corpses. In some not-unpleasant respects, the human galaxy had run out of energy.

The visitor laughed.

'We shall see, Istinbat. We shall see.'

'You will swear it, by.... yes, by the blood of your ancestors. Or I will not tell you where to listen.'

'Oh, very well. I so swear that you shall live.... if you can call this living.'

'Do not despise the Dome, star-stranger. Has it not kept Tajalam's secret for you for a thousand years?'

'Yes, actually that's the only good reason for its existence! Plus, I suppose, the luring of a few scraps of trade to this backwater.'

Istinbat shook his head.

'There's more than that. Much more. Here is the essence of hundreds of millions of people. Here is the last surviving breath of their souls, now that they are dead. True, some are vain and some are fatuous, but it is what they were. And that's enough.'

'The door, man! Unlock the door. Now!'

Istinbat considered the inscription, then led the visitor half way around the Dome. With his foot he tapped the end of one word in the black marble. With his finger he pointed to the corresponding word above. With a mocking grin, the visitor retrieved the bandage from Istinbat's hand and stuck it back over his lips. Slowly, very slowly, he moved forward.

Supremely alert, the burly man sifted through a thousand voices — confident, petulant, brash, boastful, yearning — before one harsh, regal voice spoke to him; and he froze utterly. Until now, for an hour and more, he had been moving in infinite slow motion. Now he did not move at all. He was a statue.

'I am Tajalam,' said the voice. 'My son! My heir Tajasanid!'

But Tajasanid, son of Tajalam, was dead a thousand years since — caught by the wolves, in disguise, on Praesepe Prime itself.

'You seek the key that will unlock the door to Paradise, as I sought it too. Meanwhile, the enemies increase. The assassins bestir themselves. The carrion fowl gather. I know you, my son, and I love you. How to save you from yourself, as I was never saved from myself? Let me tell you, Tajasanid, that the forging of an empire is simply *forgery*. It is the production of counterfeit — whereas a single man may become true gold himself. Remember our battle-code command for wreaking havoc and laying waste a world: 'Wilderness is Paradise enough!' There is no alien paradise planet to inherit, my son, except for the Paradise that you will make for yourself in the wilderness of exile, and simplicity. Howl now, my heir, but heed my words in time. I hope you will learn how wilderness may be truly paradise enough. I learnt it too late — but I shall write it in my blood for you to find. This is my legacy. Farewell — and blessings!'

The visitor tore the seal from his lips, and howled. He hit out at the air, as though he could strike Tajalam himself across the face, but his blows only met air.

Before Istinbat could intervene, the visitor stepped back across the black marble strip of his own accord.

continued on page 16 >

YOU ARE IN A COLD, DARK ROOM...

You hear a steady, regular shuffling sound and an occasional grunt which tells you that something else is here with you. But you cannot see what it is!

The hair on your neck rises in anticipation. You break out in a cold sweat. Terror strikes deep into your very soul. You must act quickly — but what will you do?

- Will you
- a) Feel around the walls for a light switch? (Turn to page 18)
 - b) Draw your weapon and strike blindly at the unnamed horror? (Turn to page 20)
 - c) Run for your life? (Turn to page 29)

Turn to the page indicated in one of the above options to find the results of your decision.

SOUTHSEA MODELS

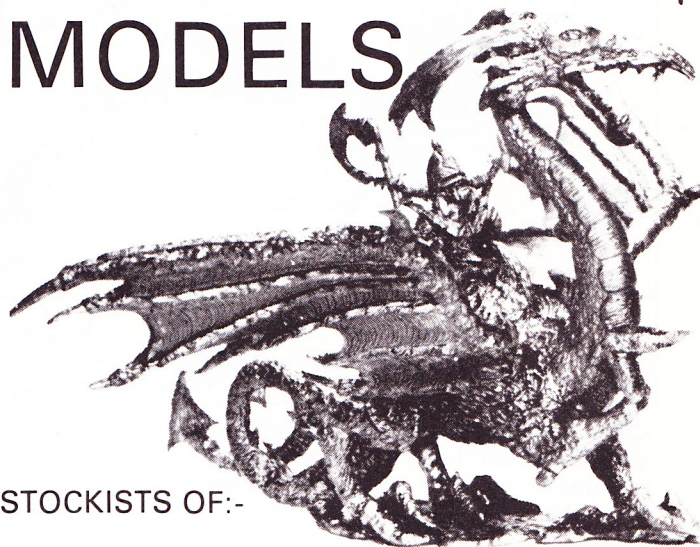

STOCKISTS OF:-

ALL LEADING MAKES OF WARGAMES, FANTASY GAMES FIGURES. FANTASY & MILITARY.

BY CITADEL AND MINIFIGS.

35 HIGHLAND ROAD
SOUTHSEA
PORTSMOUTH - HANTS
PO4 9DA
(0705)-733208

SEND 20p STAMP FOR
POSTAL CATALOGUE.
OVERSEAS 50p.

Cyril Howe Ltd.

13-14 Cheap Street
Bath Tel:60444

FOR EVERYTHING

Fantasy & Sci-fi

D&D, AD&D,
RUNEQUEST,
TRAVELLER, T&T,
JUDGE DREDD ETC.
CITADEL, BOOKS &
MAGAZINES ETC.

COME WITH US TO ANOTHER WORLD... THE TWILIGHT ZONE

PLUS

... news of all the forthcoming screen fantasy events, behind-the-scenes reports on the making of major fantasy movies ...

... reviews of science fiction, horror and fantasy films as they appear in local cinemas with no, repeat *no*, punches pulled ...

... interviews with the well-known (and not-so-famous) stars and technicians of the fantasy genre. What more could a fan ask?



STARBURST

ON SALE
SEPT 1st

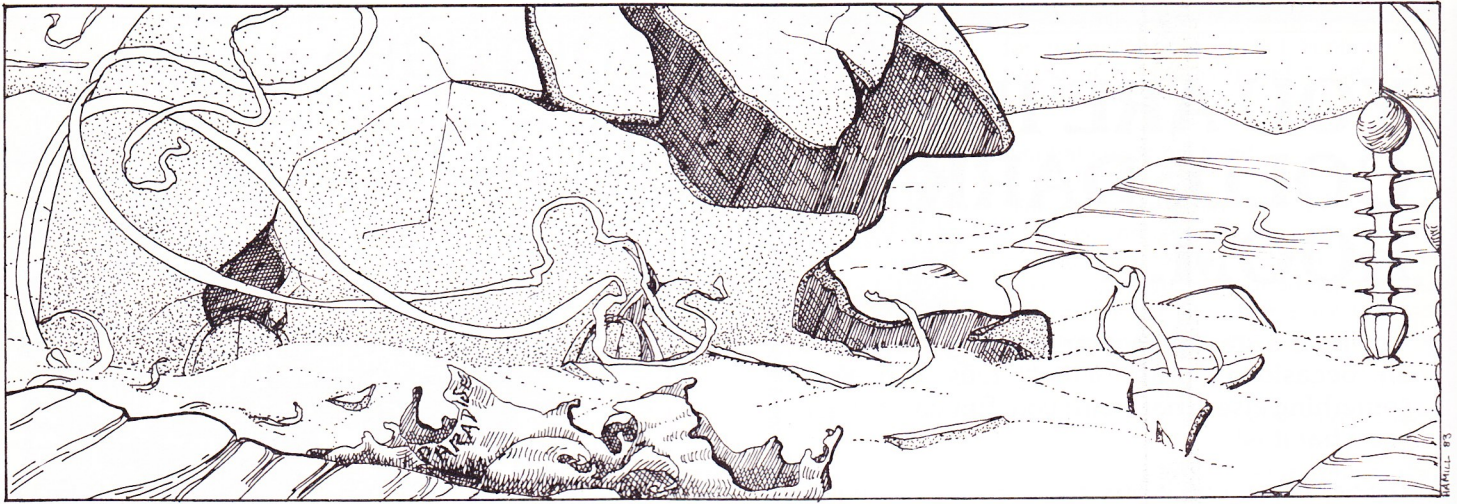

Controlling himself, the visitor said to the guardian, 'Didn't I say that there was only one good reason for this Dome's existence? Well, didn't I?'

'What did Tajalam say to you?'

The visitor spat on the floor.

'Barbarian wisdom! Now that that single reason has gone, my friend, and now that the reason for my own life has gone together with it... well, I did promise you your life, and there's small reason to break my promise now! So be warned, do not remain in this Dome today. This Dome is a trap for fools — for millions of idiots. Here is the temple of folly of all the galaxy. I do not suffer fools gladly, even though I am one myself.'

The visitor strode away towards the mouth of the spiral stairway.

'What do you mean to do?' cried Istinbat, hurrying after him.

'I shall put an end to folly, honourably, as Tajalam put an end to his own folly. Stay out of this Dome!'

'But I *guard* this Dome.'

'Guard it from the outer doorway, then!'

'What can one man do?' Istinbat laughed. He twitched his taper alight again. 'I am a fool too. I thought this was an Event. It is no event at all. Nor are your threats an event. You did not even speak them aloud, so that future visitors can hear and wonder. You only howled like a beast. Your howl whispers round the wall forever, now, until time wears the Dome away.'

Istinbat reached the base of the stairway, where the visitor was necessarily forced to wait for his way to be lit. Istinbat led him quickly along the tunnel.

'I have told you,' the visitor repeated. 'You, who wish for an Event. I promise you there will be an Event.'

Ignoring the woman Tasamma, sitting inside the doorway, the visitor retrieved his computer bracelet and strode away,

brushing aside a few brown people with flashing teeth who rushed to him from their stalls.

Istinbat watched him go. The visitor did not look back.

Half an hour later, still sitting together in golden silence, Istinbat and Tasamma saw a small hyperboat rise up into the cloudless sky from the desert beyond Wakil City. But it did not shrink to a speck, disappearing into space. Instead, it arced above the city on a tight parabola, curving back down towards them.

'It's out of control!' cried Tasamma.

Istinbat dragged her down the stone steps into the darkness of the tunnel. They huddled where they fell.

A moment later, came the crash of the explosion: an almighty thunder-shout. The tunnel floor ripped under them. A single brick fell onto Istinbat's back. Dust choked their lungs.

Coughing, they staggered back up the steps again and out onto the turquoise marble space, where vendors were running and crying out, though all apparently unhurt. The rise of the Dome above them all was intact. However, as Istinbat and Tasamma ran together around it, keeping a long way from its base, they saw that the whole western quadrant had been demolished. Pieces of marble had been tossed about the sands by the force of the explosion. The remains of the hyperboat, scattered widely, were recognizable only because they were steel not stone. The Dome was a great yawning cave, now — a broken golden egg.

As Istinbat trotted towards the great hole, a voice assailed his ears, fleetingly.

'I'll marry Lala whatever...'

And another: '*Khalwat dar anjuman...*'

And a third: '*I, Seloose of Vega, swear...*'

He stopped, appalled, bewildered. Tasamma stopped too, cocking her tall thin head.

The voices were all escaping into Suf, flying out of the hatched egg of the Dome as though from a Pandora's Box, spreading and reproducing themselves throughout the suddenly increased atmospheric volume. The phenomenon was as enigmatic, to Istinbat's mind, as the Dome itself had been.

Alone, he scrambled over the banks of rubble in the face of a tidal bore of voices, into the mouth of the cave.

He was nearly driven back by the pressure of noise, but then quite suddenly the voices became a trickle, and ceased — the flood had flowed past him.

Istinbat stepped down onto the floor of the Dome, and hurried towards the nearest intact stretch of wall. He crossed the black marble strip, and found only silence there.

Which is why the planet Suf is known as the Whispering World, or the Ghost World, nowadays; and why the brown people with flashing teeth wear plugs of wax in their ears and converse in sign language; and why more tourists pay visits to Suf, to be haunted. Generally the constant haunting is too much for the curious tourists, so that after the first five or six hours they will seek refuge in the inappropriately-named Dome of Whispers, where alone in all that world there is utter silence.

That silence has its guardians, who will not as a rule let visitors so much as whisper anywhere inside their fractured holy place. Though sometimes, for a truly golden consideration, they will allow a person to shout aloud and hear his or her voice vanish utterly without even an echo.

Nowadays there are a hundred guardians. People are eager to escape all the whispers in the world.

 Ian Watson

NOT JUST STAMPS HIGH WYCOMBE TEL: 0494 41717

EVERYTHING
FOR DUNGEONS
& DRAGONS®

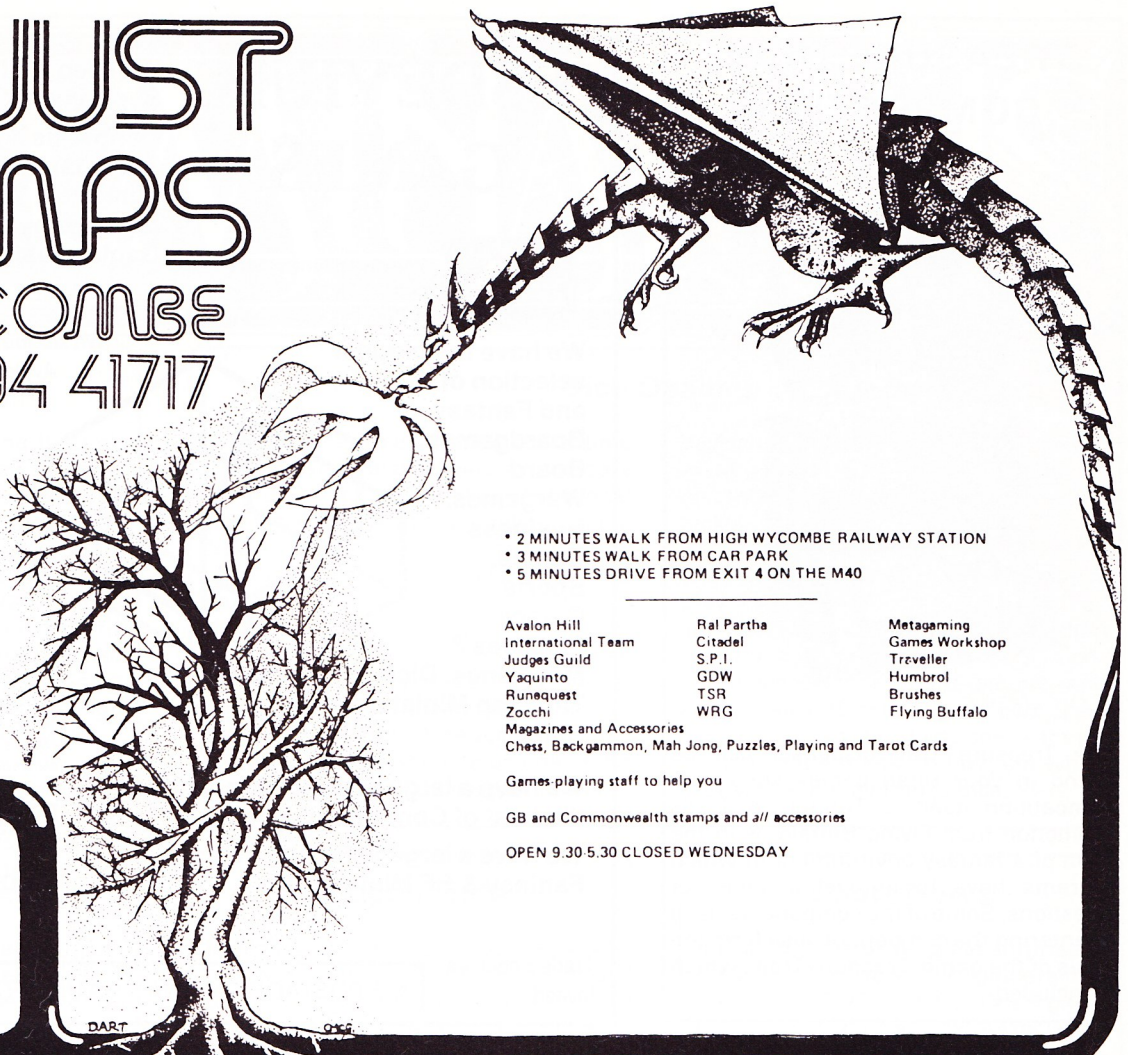

- 2 MINUTES WALK FROM HIGH WYCOMBE RAILWAY STATION
- 3 MINUTES WALK FROM CAR PARK
- 5 MINUTES DRIVE FROM EXIT 4 ON THE M40

| | | |
|--------------------|------------|----------------|
| Avalon Hill | Ral Partha | Metagaming |
| International Team | Citadel | Games Workshop |
| Judges Guild | S.P.I. | Traveller |
| Yaquinto | GDW | Humbrol |
| Runequest | TSR | Brushes |
| Zocchi | WRG | Flying Buffalo |

Magazines and Accessories
Chess, Backgammon, Mah Jong, Puzzles, Playing and Tarot Cards

Games-playing staff to help you

GB and Commonwealth stamps and all accessories

OPEN 9.30-5.30 CLOSED WEDNESDAY



TAMWORTH GAMES CENTRE

For:-

FANTASY - SCI-FI - WAR GAMES
RULES - SUPPLEMENTS - BOOKS
MAGAZINES - DICE - FIGURES
PAINTS - FELT - etc.

T.S.R. - TRAVELLER - G.D.W.
D&D - RUNEQUEST - T&T
YAQUINTO - JUDGES GUILD
CITADEL - GAMES WORKSHOP
MERIT - EON - HUMBROL
TAMIYA

Mail Order Please add p&p.
UK 10% (min. 50p) Overseas 25%.
Please allow 14 days for delivery

GILLS'S TOYS & HOBBIES
11 Market Street, Tamworth, STAFFS.
Tel: 0827-3979



IT'S NOT ALL GLAMOUR!

the magazine of
cinema & television
fantasy

FEATURING...

... news of all the forthcoming screen
fantasy events, behind-the-scenes reports on
the making of major fantasy movies...

... reviews of science fiction, horror and
fantasy films as they appear in local cinemas
with no, repeat no, punches pulled...

... interviews with the well-known (and not-
so-famous) stars and technicians of the
fantasy genre. What more could a fan ask?

EVERY MONTH!

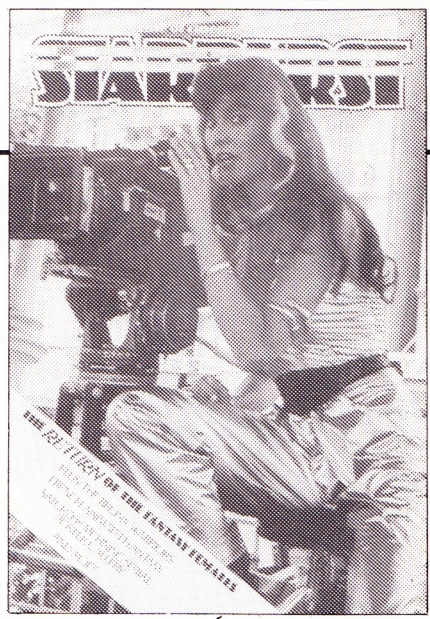

STARBURST™

TREASURE TRAIL COMPETITION



The Treasure Trail dispenser can be found in your retail games shop. The competition itself, a Tunnels & Trolls promotion from Flying Buffalo, is in the form of a fantasy environment in which entrants have to unravel a series of questions. Some of the components used in entering the competition also form the basis of the game 'Treasure Trail', which is included.

ESDEVIVUM GAMES



You may phone orders
and pay by
ACCESS

We have the biggest
selection of SF
and Fantasy
Boardgames,
Board
Wargames,
Business
Games,
Sports
Games,
Fanzines &
Magazines, Dice,
Tabletop Miniatures
Rules . . .

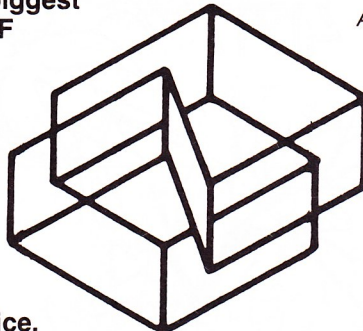

We have a large and growing range of
the best of Computer Games

We have a large selection of
Fantasy & SF Miniatures . . .

We keep the full range of Books, Rules,
Supplements and Accessories for:

**Dungeons & Dragons, AD&D,
Traveller, RuneQuest, Space Opera,
Tunnels & Trolls, Ysgarth and all the
other many and varied Role-Playing
Games available.**

We sell the full range of products from
Avalon-Hill, TSR, GDW, SPI, HP
Gibson, Eon, Games Workshop,
Judges Guild, MGC, FGU,
SJK, Yaquinto, TaskForce,
Newbury, WRG, HT, TT,
Ysgarth, International Team,
Dragon Tree . . .

**Open 5 days a week
(Closed all Wednesday)**

*Our catalogue contains details of virtually all
games available in the U.K. Send 16p in stamps &
15½p s.a.e. (overseas 4 i.r.c.) for a copy (or free
with orders over £4.00)*

ESDEVIVUM GAMES (16)
185 Victoria Road
ALDRSHOT Hants GU11 1JU
Tel: Aldershot 311443
or (evenings) Farnham 722269

Trade Enquiries
Invited.

NO POSTAGE ON MANY GAMES FOR REGULAR CUSTOMERS

the most dangerous game...

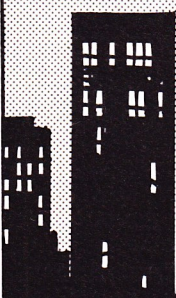

The most famous Marvel
character of all—Spider-
Man—battles the world's
weirdest foes every week in
his own magazine, Spider-
Man Weekly.
Make sure you don't miss
a single episode in Spidey's
life or death struggle with
the forces of evil, brought
to you by the world's top
writers and artists.
Spider-Man Weekly . . .
Britain's top super-hero
adventure comic — from
all good newsagents!
NOW!

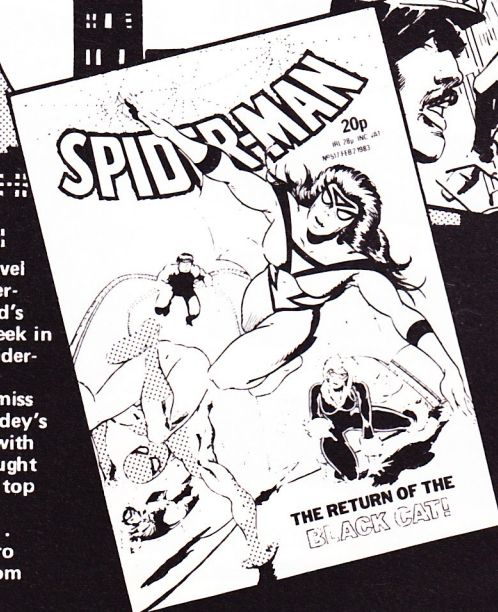

While the city sleeps, the
blind adventurer Daredevil
prowls the asphalt jungle
hunting the most danger-
ous game — Man!
Under the hand of
America's foremost strip
illustrator, Frank Miller,
the world of Daredevil is a
dark, shadowy domain of
shady underworld
characters and ruthless
criminals. Only one man
stands between the citizens
of New York and the
denizens of the Badlands
Daredevil!

a) Reaching slowly behind
you, you find the switch on
the wall. Light floods the
room. There in front of you
sits a large, hairy creature,
engrossed in a book.
Drawing closer you observe
that the book is called Blue
Frog Tavern, one of the
many solo adventures
available with Tunnels &
Trolls role-playing system.

As you hack off the
creature's head, you realise
that only this Tunnels &
Trolls solo adventure saved
you from certain death. You
leave the room, determined
to find out more. GOTO

FLYING BUFFALO

P.O. Box 100, Bath Street,
Walsall, W. Midlands.



LUMINATION

Aramax the Gaul

While you've been sweating through your favourite dungeon or swaggering round the bars of some noisome adventurers' town, have you ever spared a thought for our neighbours across the Channel? There are plenty of keen players of the D&D® game among the Gauls and until recently they have had to battle through English rules as well as the more common problems of monsters and malign magic. Ever quick to improve the lot of devoted players, TSR have now produced a French translation of Basic. Naturally this has pleased the French greatly and there are reports that other manufacturers will soon follow suit with their own translations.

The Adventure Games scene is certainly buzzing in France. There are half a dozen shops in Paris alone and quite a number of magazines. Role-playing games recently reviewed in depth include **Bushido** and **Villains and Vigilantes**. For some reason the rather obscure **Bunnies & Burrows** seems to be a French favourite. There's no doubt that Adventure Games are becoming truly international. Next stop Moscow?

IMAGINE™ magazine would like to thank Doug Cowie for his assistance with these items.

Racing Cars

Car Wars Expansion 2 is now available at around £2.25 — but what a disappointment. It contains the extra counters and turning template as promised, but no maps! According to the advance blurb there should be two maps to add to those included in **Sunday Drivers**, giving a big extension to the coverage of the town of Midville. However, there are no such maps in any of the Expansions seen so far. Either they were left out of a batch by mistake or the publisher changed his mind. So make sure you have a good look at Expansion 2 before buying. Without the maps you are paying a lot of money for some counters and a little cardboard turning template. Caveat emptor!

Dice Dealing

We old timers can remember a time when polyhedral dice were a necessary tool for games playing. Very functional and more than a little difficult to obtain. Nowadays they are marketed as being desirable objects in their own right. You can even buy twee little bags to keep them safe and sound in. The last blockbuster was the d30 (thirty sided dice). 'What do you do with them?' everyone said, as they bought them in thousands. Now an American company, the Armory (who seem to be one of the main culprits in this dice proliferation)

have announced, with a certain flourish, metal-plated dice! All sizes can be obtained, plated in either copper or nickel.

They will be \$1 each, which means they'll be about 80p in real money. The educated elite of our hobby: Guardian readers, computer programmers, module designers, assistant editors and similar riff-raff, will sneer down their elegant noses but just you see — they'll be first in the queue to buy 'em when they arrive. Funny things dice.

Nippon Nuts

Bushido, the role-playing game of medieval Japan, is one of the most popular 'hard core' games. However, it is hampered by a paucity of scenarios and supplements. So far FGU, the publishers, have only produced one. This is **Valley of the Mists**, a 'scenario pack'. A second pack, **Shadow of the Ninja**, was announced last year but so far has failed to materialise. Gloom and despondancy among Bushido buffs everywhere. But all is not lost! Enter stage left Nick Lund, flaxen-haired ex-thespian and now supremo of Chronicle Miniatures. Grieved almost beyond recall by the sight of deprived Nippon-nuts, Nick has gallantly written a Bushido adventure himself (where *does* he get the time?). Subject to the game designers approving his interpretation of their creation, this scenario pack will be UK-produced and available later this year.

Travelling Light

Just in case you have not been properly confused by **Basic Traveller** being superceded by **De Luxe Traveller** and then reappearing, followed by **Hard Back Traveller**, GDW have released **Starter Edition Traveller**. This is described as a streamlined and revised version, intended for novices. It includes special introductory material plus the adventures **Shadows** and **Mission on Mithril**. Also announced is Adventure 9, **Nomads of the World-Ocean**, set on the waterworld of Bellerophon.

Chart News

It should come as no great surprise to the majority of adventure gamers that the **DUNGEONS & DRAGONS™** game came top in the National Association of Toy Retailers' (NATR) sales charts — Board Games category — in June, above **Connect 4**, **Scrabble** and **Monopoly**. 'But it isn't a board game!' you cry. However, since there's no great satisfaction to be gained from being top of a class of one, it's an acceptable compromise.

More evidence that the hobby is on the upsurge can be found in the best-selling book lists. Games Workshop's **Warlock on Firetop Mountain** was top of the Children's Bestsellers earlier this year, with **Forest of Doom** and **Citadel of Chaos** in 3rd and 7th places respectively.

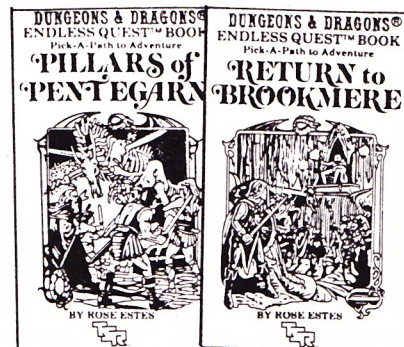

Meanwhile TSR's **ENDLESS QUEST™** books occupied five of the top ten places in the Dalton Bookseller Juvenile Paperback Bestseller List in the USA in April, including **Revenge of the Rainbow Dragons** in first place, **Revolt of the Dwarves** in 2nd place and **Pillars of Pentegarn** in 6th place.

RUNEQUEST

The Fantasy Role-Playing Game

RuneQuest is the easy-to-play game of fantasy role-playing, set in the mythical world of Glorantha. It's a game world inhabited by fighting men, gruesome monsters and savage non-human races such as the vile, chaos-spawned beastmen, Broo.

Player characters begin as young commoners or noblemen adventuring in a time and place where magic is real and heroes are in demand. They can become powerful fighters, formidable magic users or wily thieves - but only if they survive the perils of Glorantha. With **RuneQuest**, player-characters can even be non-humans, players can accept the challenge of thinking and acting like mighty Trolls or mysterious Dragonewts.

The **RuneQuest** boxed set contains everything needed to begin play: *Basic Role-Playing*, easy rules for the novice adventure gamer; *RuneQuest rules book*, advanced rules for refereed adventure; *Apple Lane and the Rainbow Mounds*, two introductory adventures set in Glorantha; *Fangs*, ready-to-roam monsters and adventurers, and six polyhedral dice. Add your imagination and you can begin your adventure.

* **RuneQuest** provides easy rules for beginning adventure gamers. There are solo adventures too.

* **RuneQuest** is ideal for experienced players, bored with dungeon adventure. *Questworld* is an adventure world which will be developed by **Games Workshop** in association with UK **RuneQuest** players.

SEE RUNEQUEST AT YOUR LOCAL GAMES SHOP TODAY

RuneQuest is published by **Chaosium Inc.** and printed and distributed under licence in the UK by **Games Workshop Ltd.**, 27/29 Sunbeam Road, London NW10 6JP.



b) You feel your weapon slice through something fairly solid. An agonised roar invades your ears and light floods the room. There before you is a large, hairy creature holding the shattered remains of a book called *The Misty Wood*, one of the many solo adventures available with **Tunnels & Trolls** role-playing system.

"Fiend", cries the creature, "you ruined my game".
"Go and buy your own copy!"

As you back out of the room, you wonder about this **Tunnels & Trolls** solo adventure which means so much, even to hairy monsters. You leave, determined to find out more. GOTO

FLYING BUFFALO

P.O. Box 100, Bath Street,
Walsall, W. Midlands.



an age
undreamed of

Know, o prince, that between the years when the oceans drank Atlantis and the years of the rise of the sons of Aryas, there was an age undreamed of, when shining kingdoms lay spread across the world like blue mantles beneath the stars — Hither came Conan, the Cimmerian, black haired, sullen eyed, sword in hand. A thief, a reaver, a slayer to tread the jewelled thrones of the Earth under his sandalled feet . . .
The Nemedian Chronicles.

the eye of erlic
the Fangs of the serpent

THE BARBARIAN

Follow the sword and sorcery adventures of Conan the Barbarian in each monthly issue of his own magazine.
Available from all good newsagents!

JACK OF ALL TRADES

by Roger Hall

development
by Graeme Morris

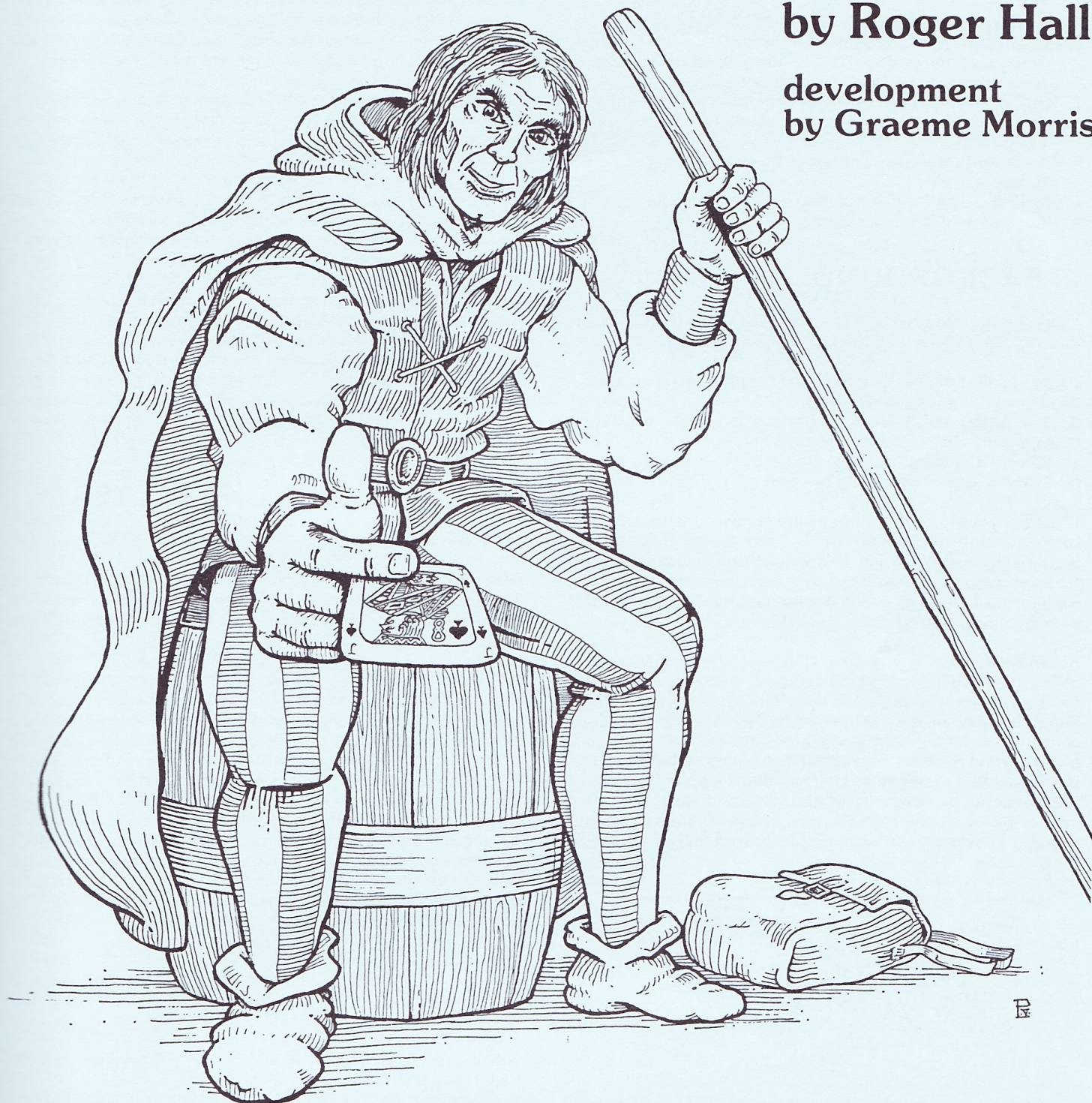

An adventure for 5-8 relatively inexperienced D&D®, AD&D™ or DRAGONQUEST™ characters.

1. INTRODUCTION

This adventure has been designed for use with the D&D, AD&D or DRAGONQUEST role-playing systems. It is intended that the characters who take part in it should not be absolute beginners but should have been on a few successful expeditions. Obviously, the fewer adventurers there are, the more experienced they should be and vice versa. The players, as distinct from the characters, should preferably be quite experienced although the adventure is possible for near novices.

The bulk of the adventure description consists of information which is applicable to all of the game systems. Information

which is specific to one or more system is presented in one of two ways:

(i) Details of the abilities of the non-player characters (NPCs) are given separately for each game in Part 4 — 'Non-Player Characters'.

(ii) Information occurring within the main text is bracketed and prefaced with **Basic**, **Advanced** or **DQ** as appropriate, eg '...they will find a small brooch (**Basic/Advanced** — value 50gp; **DQ** — value 150sp.)'

IF YOU INTEND TO PLAY IN THIS ADVENTURE, STOP READING HERE. ANY KNOWLEDGE OF THIS MINI-MODULE WILL RUIN YOUR ENJOYMENT AND THAT OF THE OTHER PLAYERS.

JACK OF ALL TRADES

The mini-module is divided into 5 sections:

1. Introduction (this section).
2. Background — for the games master (GM) only — in which The Knave (the principal NPC) is introduced and the events leading up to the adventure are described.
3. The Plot — The Knave's plan for exploiting the adventurers.
4. Non-Player Characters — details of the NPCs used in the adventure.
5. The Adventure — descriptions of the main events and their locations.
6. The Knave as a Thief-Acrobat — using this module to try out the new split character class.

2. BACKGROUND

This adventure centres on a character known as The Knave; an unscrupulous villain who lives by murder and theft.

Using the alias of Jack Summers, he recently set up an outlaw band to raid cargoes going to and from the small trading town of Roseberry (see map I). The outlaws have been using a deserted hulk grounded in a backwater as their hide-out (see map Ib and section 4E). Using this as a base, they have been able to prey on pack- and wagon-trains using the road to the west of the town.

Initially, the payment of bribes by the outlaws ensured that the town watch turned a blind eye, but soon some of the town's worried merchants formed a vigilante group in order to try and find the outlaws' hideout and to put a stop to the raids. The Knave, in the guise of a merchant but using the same alias of Jack Summers, joined in this group.

Recently because of the cost of bribing the watch and the strengthening of guards on the caravans, things have been bad for the outlaws and dissent in their ranks has begun to show. The Knave (known only to the outlaws as Jack Summers) has convinced his men that the vigilantes are the root of all their problems and has told them of a plan to get rid of the vigilantes. He has not told them the second part of his plan — to get rid of them and take all the goods for his own! Conditions tonight are perfect to carry out his plan, there is no moon, there is a vigilante meeting and there is a band of adventurers newly arrived in town.

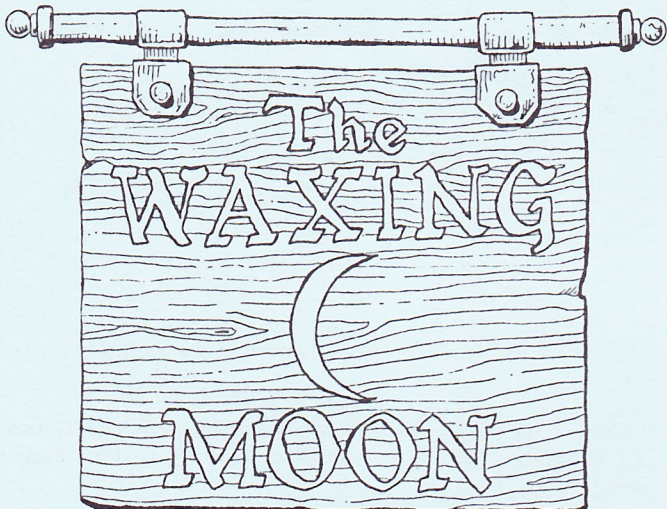

3. THE PLOT

The Knave's plan is elegant and ruthless. If successful he will dupe the adventurers into disposing of both the vigilantes and the outlaws, taking losses themselves in the process, leaving Jack to finish off the survivors and to make off with the loot.

The stages of his plan are as follows:

(i) The Knave will introduce himself to the party as Jack Summers, the merchant. He will tell them about the outlaws and will say that he has infiltrated the band.

(ii) He will persuade the adventurers to take part in a trojan-horse-style raid on the outlaws. The characters will hide in barrels which will be taken by caravan along the west road. The outlaws will attack, steal the barrels and take them to their lair where the adventurers will emerge and attack the thieves.

(iii) In fact, the outlaw attack will be a sham and the barrels will be taken to the vigilantes' headquarters where a meeting has been arranged. The Knave hopes that the adventurers will kill all or some of the vigilantes by mistake.

(iv) The outlaws know of 'Jack's' plan up to this stage and will help him with it. What they do not know is that The Knave will have planted information at the vigilantes' headquarters which will lead the adventurers to the outlaws' lair.

(v) The Knave intends that the adventurers should attack the outlaws. Then, he will finish off any survivors (from either side) and make off with the valuables of both groups.

In general, and in particular if the plan should go wrong in any way, The Knave will protect his own life first and foremost and will have no regard for the adventurers, the vigilantes or his erstwhile colleagues.

4. NON-PLAYER CHARACTERS

A. TOWNSMEN

(i). **Bert Barleyman** — Landlord of the Waxing Moon. He knows The Knave only as Jack Summers the merchant and regards him as an honest man. The Knave rents a room permanently in the Inn and Bert is used to 'Jack' holding meetings there.

(ii). **Town Guards** — The Town Guard consists of 24 men in three patrols of eight each. They are employed by the town council to protect the inhabitants and to keep order. They are a slovenly lot, reluctant to risk their skins and they will not accompany the adventurers on expeditions outside the town. This attitude is only partly the result of the men's personalities. Their major motivation is the regular bribe which they are paid by the outlaws. Recently the guards have been demanding, and getting, more and more money for their co-operation. The bribes are received from Phil Snatch, The Knave's outlaw lieutenant. Three of the guards know Phil by sight but not by name. All the guards receive bribe money. They know 'Jack Summers' only by name and do not associate him with the outlaws.

Town Guards (24 men in 3 patrols of 8)

Basic — AC 6 (leather and shield); NM; hp 1-4; # AT 1; D 1-6 (short swords); AL N; MV 90' (30'); ML 6

Personal treasure — each will have 2-12gp in mixed coins.

Advanced — AC 7 (leather and shield); FO; MV 9"; hp 1-8; # AT 1; D 1-6 (short swords); AL LN

Personal treasure — each will have 2-12gp in mixed coins.

DQ — Average characteristics for the guards are:

PS: 19 MD: 17 AG: 16 EN: 17

MA: 9 WP: 12 FT: 21 PB: 10

PC: 8

They are armed with broadswords (with which they are rank 1-2), wear leather armour while on duty and carry small round shields (with which they are rank 0-1). The leaders of each patrol have Military Science skill rank 0-1. In addition, all the guards will have 1 of the following: dagger 0-3, unarmed combat 0-2, Horsemanship 0-2, Stealth 0-1, Thief 0-1. They will each be carrying a personal treasure of 6-30sp.

(iii). **Merchants** — There are many merchants based in Roseberry, profiting from the trade along the east-west road and the river. A wide range of goods are involved, including grain, wine, beer, salt and cloth.

They have known The Knave (as Jack Summers) for a few months, but the investigation of his credentials which the merchants' guild carried out before admitting him caused no alarm, and they have found no cause for mistrusting him since.

Some merchants will know Jack better than others, of course, but the general opinion of him is that he is an honest newcomer.

(iv) **Vigilantes** — Realising that the town guards are of little use in combatting the outlaws (but unaware that they are being bribed), some of the merchants have formed a vigilante group led by Owen Carter, an ex-soldier.

Following Jack's acceptance by the merchants' guild, he joined this group and has since been strengthening his position within it. The other members of this group know little about Jack beyond his vigilante activities. He has been careful not to draw attention to himself by, for example, revealing any inside knowledge of the outlaws. To date, the vigilantes have had as much impact on the outlaws as the local knitting circle. They are not professional investigators and, of course, The Knave has kept himself and his band well ahead of the vigilantes' plans.

Despite their lack of success so far, the vigilantes are keen and committed men — at least as a group. However, they are not professional fighters and will not risk their skins unnecessarily.

Owen Carter (vigilante leader)

Basic — AC 7 (leather); F2; hp 10; # AT 1; D 1-8 (sword) or 1-4 (dagger); AL L; MV 90' (30'); ML 9.

Personal treasure — 10cp, 20sp, 15gp and a gold locket (containing a portrait of his wife) encrusted with small gems (value 350gp).

Advanced — AC 8 (leather); F1; MV 9"; hp 13; # AT 1; D 1-8 (long sword) or 1-4 (dagger); AL NG.

Personal treasure — 10cp, 20sp, 15gp and a gold locket (containing a portrait of his wife) encrusted with small gems (value 350gp).

DQ — Owen's attributes are:

PS: 14 MD: 17 AG: 16 EN: 20
MA: 10 WP: 17 FT: 22 PB: 17
PC: 9

He is armed with a sabre (rank 3) and a dagger (rank 2) and wears leather armour under his robes. His skills are: Merchant 5, Horsemanship 3, Navigator 1, Read & Write (common) 7, Troubador 0, Military Scientist 2. His personal treasure consists of 10cf, 20sp, 1gs and a gold locket (containing a portrait of his wife) encrusted with small gems (value 700sp).

Other Vigilantes (10 men)

Basic — AC 7 (leather, if worn) or 9; NM; hp 1-4; # AT 1; D 1-6 sword; AL L; MV 90' (30') or 120' (40'); ML 7.

Personal treasure — each will have 5-30gp in mixed coins plus 0-2 items of personal adornment (buckles, rings, clasps, pins etc) each worth 10-100gp.

Advanced — AC 8 (leather, if worn) or 10; F0; MV 9" or 12"; hp 1-8; # AT 1; D 1-6 (short sword); AL LG or NG.

Personal treasure — each will have 5-30gp in mixed coins plus 0-2 items of personal adornment (buckles, rings, clasps, pins etc) each worth 10-100gp.

DQ — The average abilities of the other vigilantes are:

PS: 15 MD: 16 AG: 15 EN: 19
MA: 12 WP: 13 FT: 21 PB: 15
PC: 6

They are armed with short swords (rank 0-1) and have leather armour (although only three of them habitually wear it). All of them will have rank 4-7 Merchant skill, Read & Write (common) rank 3-8 and Horsemanship rank 2-4. In addition, each will have

one of the following skills: dagger 1-2, Navigator 1-2, Healer 0-2, Mechanician 1-2, Thief 0-1. Each will have a personal treasure consisting of 10-50sp worth of mixed coins plus 0-2 items of personal adornment (buckles, rings, clasps, pins etc) each worth 20-200sp.

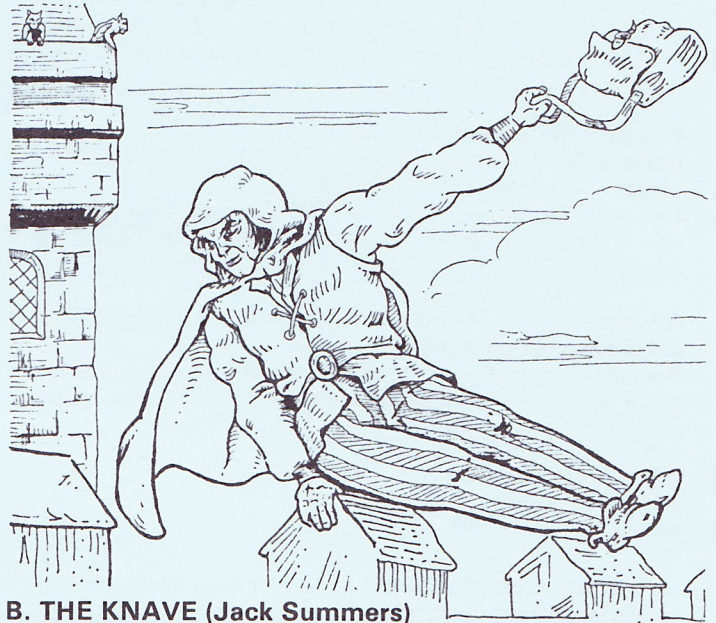

B. THE KNAVE (Jack Summers)

The Knave values his own life and profit above all other things. He has lived a life of murder and theft, adapting and discarding a string of aliases (usually taking the identity of one of his victims). His plan and intentions have been described previously. His attributes are:

Basic — AC 4 (leather plus dexterity bonus); T6; hp 16; # AT 1; D by weapon type; AL C; MV 90' (30'); ML see description; S11, I15 (speaks common, chaotic and hobgoblin), W9, D18 (+3 to hit with missiles, -3 AC bonus, +2 on initiative), C12, Ch15.

Equipment — 6 concealed daggers, crossbow, quarrels, thief's tools, key to chest in the outlaws' lair, **belt of infravision** (a special magical item which gives the wearer infravision — range 90').

Personal treasure — 20sp, 30gp, 4 gems (800gp (x2), 2000gp, 4000gp) and an exquisitely made pack of ivory playing cards (all knaves!).

Advanced — AC 4 (leather plus dexterity bonus); A6; MV 9"; hp 28; # AT 1; D by weapon type; AL LE; S11, I15 (speaks common, LE, hobgoblin, goblin and orc), W9, D18 (+3 to hit with missiles, -4 AC bonus), C12, Ch15.

Equipment — 6 concealed daggers, crossbow, quarrels, thief's tools, key to chest in the outlaws' lair, **belt of infravision** (a special magical item which gives the wearer infravision — range 90').

Personal treasure — 20sp, 30gp, 4 gems (800gp (x2), 2000gp, 4000gp) and an exquisitely made pack of ivory playing cards (all knaves!).

DQ — The Knave's attributes are:

PS: 16 MD: 20 AG: 21 EN: 19
MA: 7 WP: 8 FT: 21 PC: 13
PB: 17

The Knave is armed with 6 daggers (used at rank 8) which he conceals about his person, a short bow and arrows (rank 5) and a garotte (rank 3). He wears leather armour and carries thief's picks and the key to the chest in the outlaws' lair. His other skills are: Assassin 3, Merchant 1, Military Scientist 3, Ranger 2, Thief 7. He has a belt which has been invested with the Spell of Nightvision (College of Black Magics — S2). The spell was invested at rank 7 and has an 86% chance of success. There are 4 charges remaining. His other personal treasure consists of 10cf, 25sp, 4 gems (1000sp (x2), 2500sp, 8000sp) and an exquisitely made pack of ivory playing cards (all knaves!).

JACK OF ALL TRADES

C. OUTLAW BAND

This group of argumentative thugs has only been held together by Jack's authority and the profit which they can derive by raiding caravans under his leadership. They have known 'Jack' only since his arrival at Roseberry and are unaware of his true name. They have no loyalty to him and would kill him without a second thought if they discovered the latter part of his plan.

Phil Snatch ('Jack's' lieutenant)

Basic — AC 7 (leather); F3; hp 13; # AT 1; D 1-8 (sword) or 1-4 (dagger); AL C; MV 90'(30'); ML 7.

Personal treasure — 21 gp, a key to the chest in the outlaws' lair and a white silk scarf embroidered with gold thread (value 50gp).

Advanced — AC 7 (studded leather); F3; MV 9"; hp 18; # AT 1; D 1-8 (sword) or 1-4 (dagger); AL NE.

Personal treasure — 21 gp, a key to the chest in the outlaws' lair and a white silk scarf embroidered with gold thread (value 50gp)

DQ — Phil's attributes are:

PS: 20 MD: 15 AG: 14 EN: 19

MA: 9 WP: 12 FT: 21 PC: 7

PB: 14

He uses a broadsword (at rank 4) and a main gauche (rank 1). He wears leather armour and has a key to the chest in the outlaws' lair. His other skills are; Horsemanship 2, Stealth 1, Thief 2. His personal treasure consists of 40sp, a key to the chest in the outlaws' lair and a white silk scarf embroidered with gold thread (value 100sp).

Outlaws (8 men)

Basic — AC 7 (leather); F1; hp 1-8; # AT 1; D 1-6 (short swords) or 1-4 (dagger); AL C; MV 90' (30"); ML 8.

Personal treasure — each will have 2-20gp in mixed coins.

Advanced — AC 8 (leather); F1; MV 9"; hp 1-10; # AT 1; D 1-6 (short sword) or 1-4 (dagger); AL NE.

Personal treasure — each will have 2-20gp in mixed coins.

DQ — the average attributes of the outlaws are:

PS: 20 MD: 15 AG: 15 EN: 17

MA: 9 WP: 10 FT: 21 PC: 6

PB: 12

The outlaws use short swords (rank 1-2) and daggers (rank 0-1) and wear leather armour. All of them will have Horsemanship skill rank 1-3, and one of the following: Assassin 0-1, Spy 0-1, Thief 0-1, Read and Write (Common) 0-2. Their personal treasure will consist of 5-50sp worth of mixed coins.

5. THE ADVENTURE

The descriptions of the various stages of the adventure include sections which may be read aloud to the players by the games master. However, this should not be considered mandatory and the GM should use other descriptions if desired.

A. MEETING WITH JACK SUMMERS

Having travelled far in search of adventure you arrived barely an hour ago this evening at Roseberry. You are approached in one of the town's taverns by a man, apparently a trader, who indicates that he has some information that may well benefit you, and that if you are interested you should follow him at five minute intervals to the Waxing Moon Inn and ask the barman for Jack's room. Without awaiting your reply he leaves, looking around anxiously as he goes.

JACK OF ALL TRADES

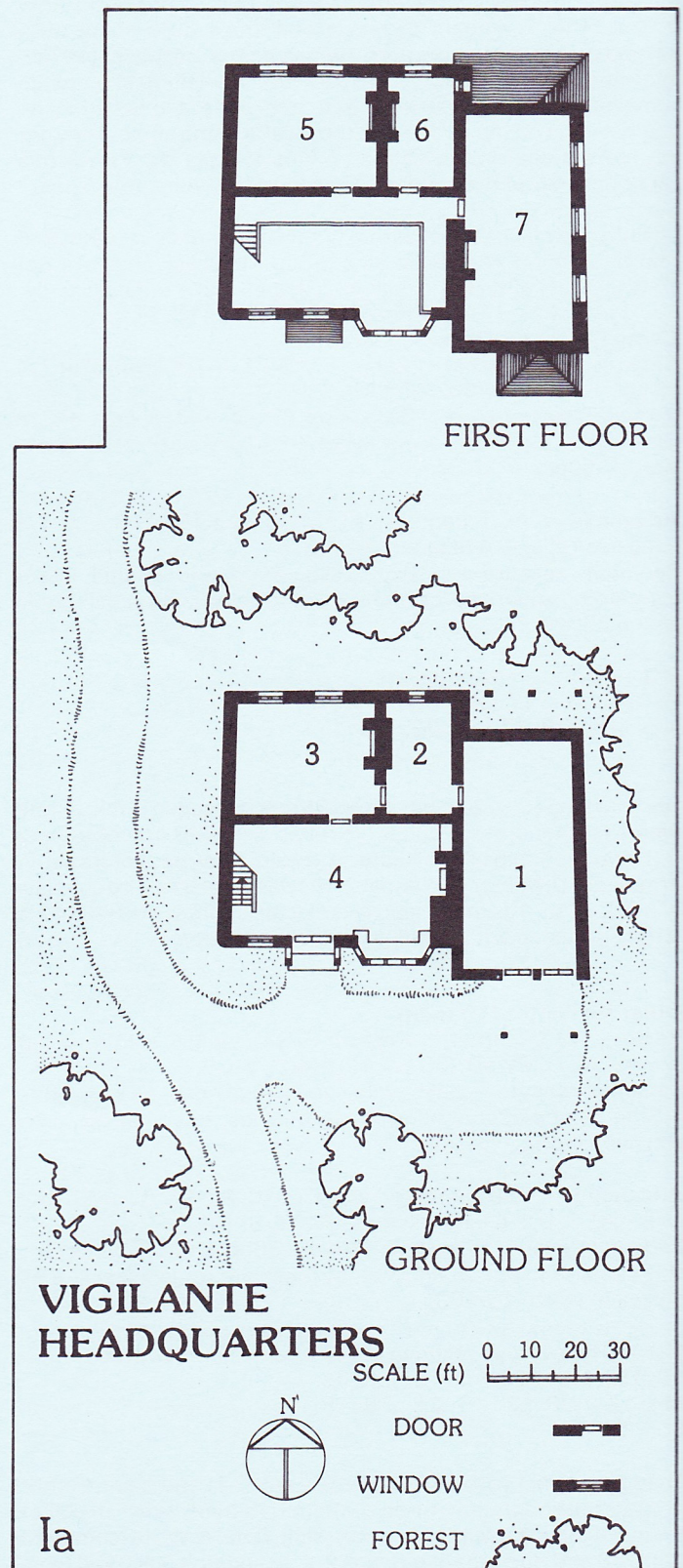

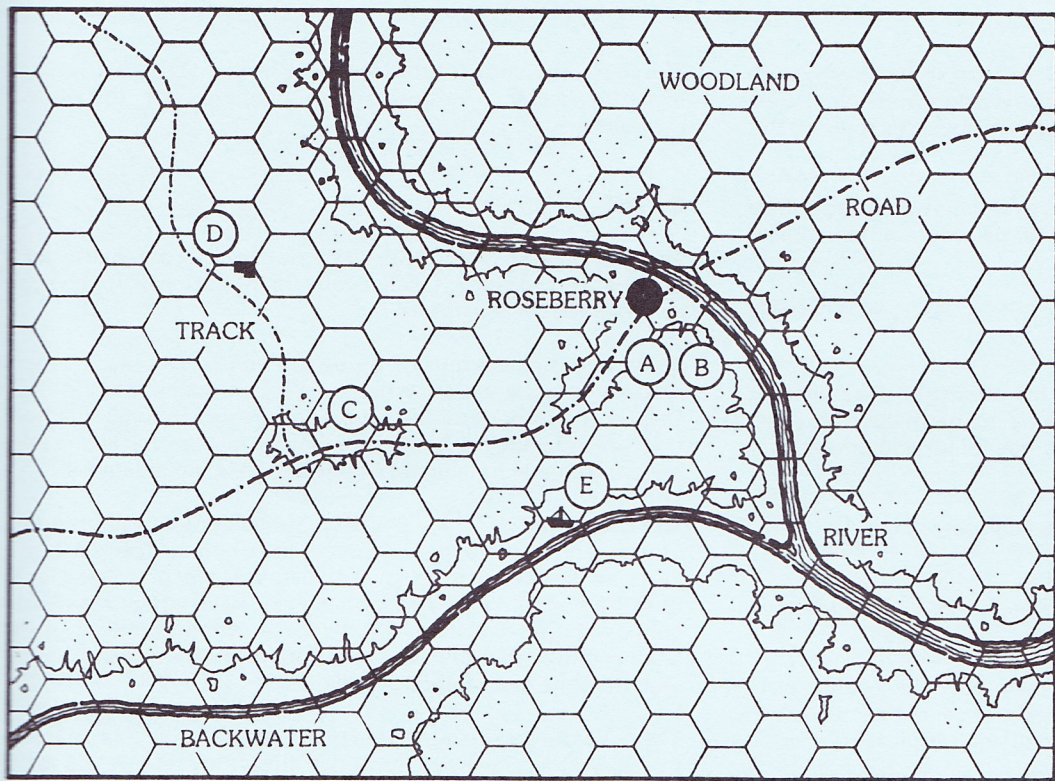

I
**THE REGION
 AROUND
 ROSEBERRY**
 (diagrammatic)

- (A) MEETING WITH JACK SUMMERS
- (B) THE WINERY
- (C) THE PHONEY AMBUSH
- (D) THE VIGILANTE H'QUARTERS
- (E) THE OUTLAWS' HIDEOUT

ONE HEX = HALF MILE

VIEW FROM ABOVE

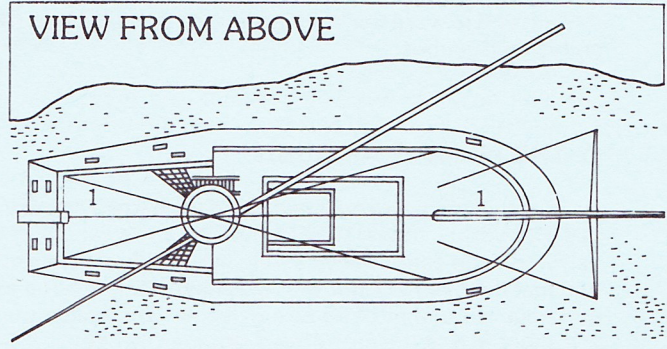

LONGITUDINAL SECTION

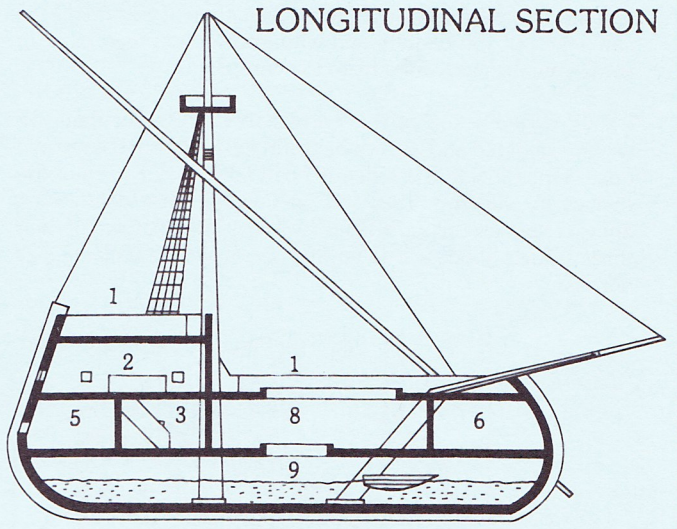

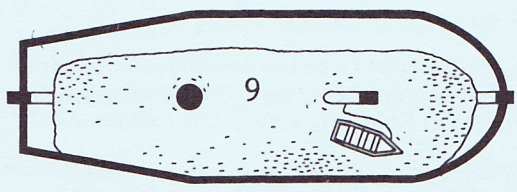
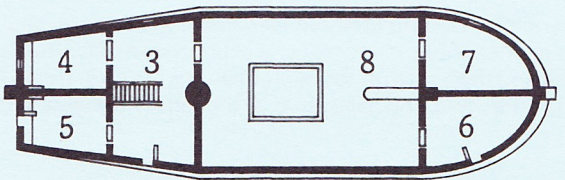
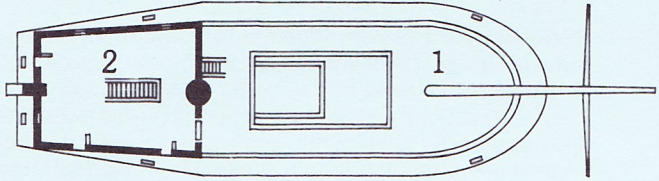

DECKS



OUTLAWS' HIDEOUT

SCALE (ft) 0 10 20 30

PORTHOLE (closed) 
 PORTHOLE (open) 

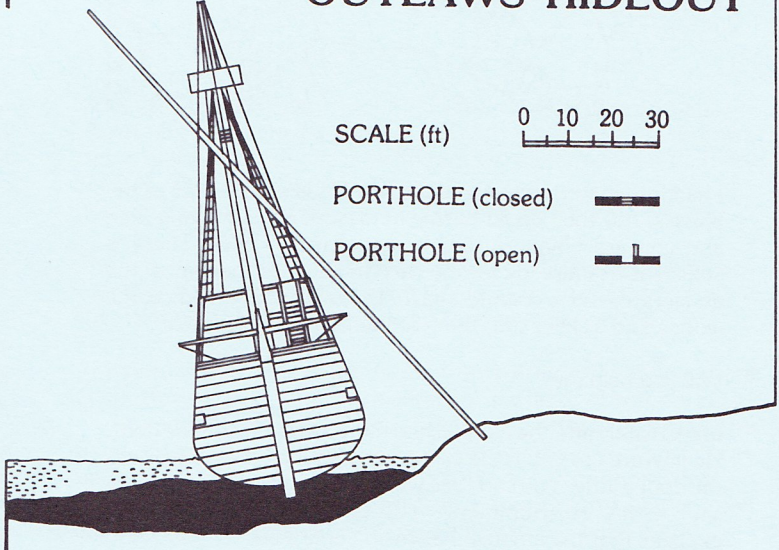

Ib

JACK OF ALL TRADES

The man is The Knave, alias Jack Summers. If the adventurers take up his invitation and go to the Waxing Moon Inn, Bert Barleycorn (the innkeeper) will direct them to Jack's room on the first floor.

Jack will be wearing leather armour under his robes and will be armed only with his daggers. He will be wearing his magical belt.

There is nothing in his room to give any impression that 'Jack' is other than a merchant.

The grey mare which he uses in his merchant guise is stabled at the inn and is similarly unincriminating. He has hidden his other horse (a black stallion) and the remainder of his equipment near the vigilantes' headquarters.

When you are assembled, the man addresses you.

'My name is Jack Summers, a merchant trading in grain and wine. For some time my caravans, and those of my fellow guildsmen, have been plagued by a band of outlaws.

'We have been powerless to stop them since the location of their lair is unknown and our town guard cannot be trusted. However, I have recently managed to contact these bandits, pretending that I wish to join them. To prove that I am in earnest, I have arranged for the outlaws to ambush a cargo of wine which I am transporting on behalf of Stan Brewer who owns the winery here in Roseberry. I am to lead two wagonloads of wine from the town within the hour. I will be ambushed and taken to the outlaw headquarters. It will be the first time I have had knowledge of its location. If you aid me we can wipe out the bandits and who knows, you may pick up some valuable souvenirs from the camp?

'I have rigged some of the barrels to carry men; they are weight-adjusted and will not be distinguished from the normal ones. Once inside the hideout I can let you out to take the thieves by surprise: they will be unwary while celebrating another successful raid and you will easily rid the town of their threat. Their goods will be yours and you will be acclaimed as heroes.



'I had intended that some of the local lads should hide in the barrels, but they could hardly be described as fighting men and you are obviously better suited to the task. There is sufficient risk already for my cart-drivers, but they know the dangers and have volunteered for the job. They both know the woods and will flee into them at the first hint of trouble.

'Will you help me?'

Immediately after he has finished there is a knock on the door. He gestures to you to be silent, crosses the room and opens the door a little. You can't see who's there but you hear a voice say — 'It's on, Summers'. The door is closed and Jack explains that the ambush has been confirmed.

The man who came to the door was in fact Owen Carter, the vigilante leader, confirming the meeting, and the Knave capitalised on the event.

B. THE WINERY

The winery is deserted. The building is in a quiet part of the town and the yard has a high wall. Events in the yard will not be seen or remarked on by passers-by.

Assuming the adventurers agree to The Knave's plan, he will lead them to the winery where he will introduce them to Stan Brewer, the proprietor, and the two cart-drivers who will help them into the barrels. Make sure that the player-characters take only reasonable equipment into the barrels, no polearms!

The 'proprietor' is, in fact, Phil Snatch (Jack's outlaw lieutenant). The cart-drivers are also members of the band. There are two carts, each capable of carrying 7 barrels (a layer of 3 over a layer of 4). The bottom 4 barrels on each cart have been prepared to conceal the adventurers. If there are less than 8 adventurers, Jack and the other men will take apparent care to make up the weight of the unoccupied barrels.

The adventurers are quite able to get out of the barrels unaided, but it will be obvious to them that they would be at a considerable disadvantage if they attempted this in the presence of hostile creatures (**Basic/Advanced/DQ** — there would be a 50% chance of the party being surprised and they would automatically lose initiative in the first round/pulse thereafter). Jack's final words to the adventurers will be to point this out and to warn them not to emerge except in emergency or on his instructions.

C. THE PHONEY AMBUSH

Once the adventurers are installed in the barrels, the GM should describe what follows. They cannot see out (a barrel supposedly carrying wine cannot have a hole in the side) so they only hear and feel the events. After the carts have been moving for about one hour, a number of horses arrive, orders to stop the wagon are shouted and the cart-drivers apparently flee.

The 'raid' will involve 3 further members of the outlaw band. They are on horseback, and bring 2 spare horses with them.

There follows a pre-arranged conversation between Jack and the outlaws. In it, the outlaws congratulate Jack on the success of the raid and invite him to come with them to the hideout to meet the rest of the gang and to be fully initiated. Jack accepts and the outlaws tell him that some of them will ride ahead of the carts while others follow at a distance to cover their tracks. Jack and one of the outlaws will drive the carts.

There is the sound of horses leaving and the carts beginning to move once more. They travel a short distance further along the road and then turn off to the right onto a rougher track. About an hour after this, the carts stop at the vigilantes' headquarters.

D. THE VIGILANTE HEADQUARTERS (see maps I and Ia)

This is an abandoned wooden building beside a little-used track about 6 miles from Roseberry. The building was originally an inn, but few in Roseberry know of its existence.

The vigilantes spend periods of several days or more here, explaining their absences as business trips. They have made the inn relatively comfortable and have brought in supplies to sustain them during their stays.

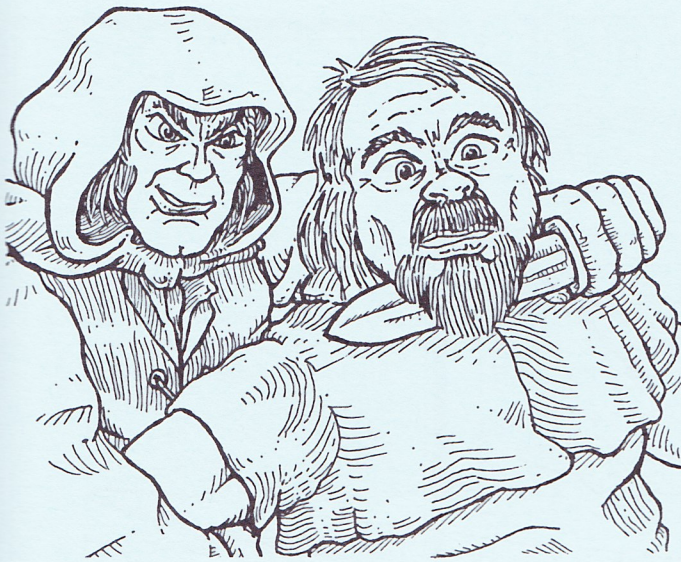

This evening, the group is expecting Jack to arrive with a load of wine for the store. The real owner of the winery is a member of the vigilante group and arranged for the winery to be empty while Jack loaded his carts, unaware that his trust would be so abused.

When the carts arrive at the inn, they will be taken into the stables (room 1). The adventurers will feel the carts stop, hear the doors open, feel the carts move again and hear the doors close. Next, the outlaw driving the second cart will tell Jack to leave the carts and to go with him to see the others. The two will then leave and the adventurers will hear the side-door close. The outlaw will attempt to leave through the store-room window but The Knave will kill him quietly and bundle his body out before going into the hall. The Knave will return to the stables after about two minutes and will begin to help the characters out of the barrel. Once about half of the group are freed;

The side-door opens and a man steps in, saying 'Hurry up with that wine, Ja...'. He stares dumbstruck at you. Quickly, Jack grabs him and has a dagger at his throat in a flash. 'Get the rest!' he snaps, pointing through the open doorway.

The Knave did not intend this intrusion to happen but he will capitalise on it by killing the man and then slipping away while the players are occupied.

His plan is that the adventurers, thinking that they are in the outlaw camp, will kill the vigilantes for him. The first part of his plan will then be over and the second part will begin.

Before he slips away, Jack will plant information on the clothing of the vigilante he has killed. It will consist of 2 pieces of parchment, the first saying '*Suspected Codename of Outlaw - Knave*', and the other being a map, entitled '*Suspected Location of Outlaw Hideout*'. The map marks with a cross the position of the hulk which the outlaws use as a hideout.

Even if the adventurers manage to kill all of the vigilantes, they should still discover their error in attacking them since the merchants' identities will be clear from the documents etc which they carry.

KEY TO ROOMS IN THE INN

1. Stables — There are 11 unsaddled horses here; which belong to the vigilantes. The Knave's horse is hidden in the woods behind the inn.

2. Pantry/Storeroom — This room is used to store foodstuffs and the other portable equipment and stores of the inn. In addition to the new stuff brought by the vigilantes, there is also the residue of the previous occupants.

3. Kitchen — Since they are unused to fending for themselves, the vigilantes have done only the minimum amount of work necessary in the kitchen to make it usable.

4. Hall — This was the main room of the inn. Stairs run up the western wall, leading to a gallery which runs along the northern and eastern sides. The doors of the inn's upper rooms open out onto this gallery.

With the exception of the vigilantes killed by The Knave, the entire group will be assembled in this room when the adventurers are freed from the barrels. Only Owen Carter and three of the other vigilantes habitually wear armour but all bear arms while at the inn. The room's only furnishings are a long table around which the vigilantes are gathered, and the chairs on which some of them are seated. Stacked against the eastern wall are the vigilantes' packs and saddles.

The vigilantes will not have heard the demise of the outlaw or their comrade, nor will they be alarmed by the unhurried footsteps of a small number of people in the store and kitchen. They are generally wary, however, and unexpected noises will not go unnoticed....

5. & 6. Bedrooms — These rooms are mostly empty, containing only a little broken furniture etc. left by the previous occupants. The vigilantes have not reoccupied these rooms.

7. Dormitory — This room has been swept clean by the vigilantes and now contains their bed-rolls.

E. OUTLAWS' HIDEOUT (see maps I and Ib)

For their hide-out, the outlaws have chosen an old cargo-boat which lies grounded by the bank of a tributary of the main river. It has been there for many years, and it is a damp, uncomfortable place to live. Apart from this, however, it is ideal for their purpose. Only the infrequent users of this backwater even know of the hulk's existence and, with one exception, they take no notice of it. The exception is the crooked captain of a cargo-boat which plies the main river. This captain brings a long-boat up the back-water once a month in order to buy any goods which the outlaws have stolen. He then re-sells these goods at a profit far from Roseberry.

Even at their most alert, the outlaws' system of watches was lax. Tonight, however, they are keeping no watch at all, confident that the vigilantes have been destroyed.

The positions given for the outlaws in the key below assume that they are unaware of the adventurers. If the alarm is raised, of course, the outlaws will attack the party en masse. The outlaws wear armour and carry weapons at all times.

KEY TO THE HULK

Note that the hulk is grounded on the river-bed at an angle of about 10 degrees to the vertical. All of the timbers of the hull are damp but the dampness is worse on the lower decks which are rotting. The boat will not burn without, for example, the presence of burning oil — and then only reluctantly.

The portholes of the boat are all about 18" square and have wooden shutters which may be locked from the inside. Most of the portholes on the side nearest the bank are closed.

Between the hulk and the bank, the river is only about a foot deep. However, the bed here consists of a layer of soft mud (see cross-section, map Ib) which makes an effective moat. The usual means of boarding the hulk is along the lower part of the boom which rests on the bank. If looked for, the foot-prints on the bank near the boom and the marks on the boom itself (caused by the outlaws climbing on it) will easily be seen.



1. Deck and Rigging — The deck area is deserted, and there are no indications here that the hulk is occupied.

The mast, boom and bowsprit are intact, as are most of the rigging ropes, but the sails have all been removed.

2. Upper Cabin — the outlaws' use this as a common-room. Also, since it is one of the least damp cabins in the hulk, most of the outlaws sleep here.

In the room when the party arrive are Phil Snatch and two other outlaws. They are seated around a table at the western end of the cabin drinking ale. They will call for help if attacked.

The other contents of the cabin are eight hammocks, some stores of food and drink, a small stove, some fire-wood, some kitchen utensils and a chest. The chest is securely bolted to the deck. It has three locks, the keys to which are held by The Knave, Phil Snatch and one of the outlaws (their 'representative') respectively.

The chest is locked (**Basic/Advanced** — normal thief's chance of picking each lock; **DQ** — each lock is rank 3) and trapped with a slashing blade device. Unless the trap is discovered and neutralised the blade (which is 3 feet long) will swing out and around in a circle about 2 feet above the ground (**Basic/Advanced** — normal thief's chance to find/disarm, blade strikes as if a 3 HD monster and does 1-8 points of damage; **DQ** — the trap is rank 3, the blade has a strike chance of 60% and a damage modifier of +1).

The chest contains the money paid by the crooked captain (**Basic/Advanced** — 1500gp in mixed coins; **DQ** — 2000sp in mixed coins).

3. Store — The northern (drier) part of this cabin is used by the outlaws to store their plunder. Currently, there are 6 bales of cloth, 2 casks of tobacco and 4 jars of spices here (total value — **Basic/Advanced** 100gp; **DQ** 200sp).

The remaining 5 outlaws are here, including the one who has the key to the chest in room 2.

4. Phil Snatch's Cabin — The contents of this cabin are simple; a hammock, a table, 2 stools and a wooden box containing some clothes. Phil does not trust his companions enough to leave anything of value here!

5. & 6. Empty Cabins — These cabins are too damp for occupation and contain only rubbish.

7. The Knave's Cabin — This cabin contains only a hammock. The Knave is even less trusting than Phil.

8. Upper Hold — This area is empty. There is a hidden rope hanging from the south eastern corner of the large hatch which allows access to the rowing-boat below.

9. Main Hold — This part of the hulk is flooded. Floating here (and moored so as to be hidden from above) is a rowing boat. In addition to oars, the boat has 2 large axes in it. In case of emergency, these would be used to hack through the rotting hull and the boat would provide a means of escape down the river.

AMBUSH BY THE KNAVE.

The Knave will have made haste from the inn and will almost certainly be here before the adventurers. He will not have gone on board, however, but will have concealed himself in the angle of a tree overlooking the hulk. His horse will be tied nearby. Using his belt and thief skills he will be able to avoid the adventurers when they arrive.

When the survivors of the fight on the hulk emerge, he will open fire on them. If it seems that he can kill them all easily, he will continue firing. If it seems that his life might be in danger, he will attempt to slip away.

6. THE KNAVE AS A THIEF-ACROBAT

The final scene of this module (the hulk) is an ideal setting in which to try out the thief-acrobat, and you might like to try giving The Knave this split class if you are running an AD&D™ adventure.

The Knave's level should remain the same (6) but his strength must be increased to 15 and darts should be exchanged for the crossbow and quarrels.

The thought of The Knave ambushing the survivors of the fight from the crow's nest by sending down a rain of darts and then escaping Douglas Fairbanks-style by climbing down the rigging, balancing along the boom or leaping to the bank is quite attractive....

CREDITS

Design:
Development:
Art:

Roger Hall
Graeme Morris
Paul Ruiz
Pete Young

c) As you turn and flee, you run straight into the wall. SMACK! Stunned, but still standing, you feel around the wall desperately for some means of escape. But you find only a light switch.

Determined to at least face your nameless foe, you turn, finger hovering over the switch. Turn to page 18 (option a).

Keep Your Imagination Under Wraps

IMAGINE™ magazine binders are now available to keep your favourite magazine safe from the ravages of time. Finished in a choice of colours (*blue — we chose it*) and tastefully adorned with our logo, the binders will hold 12 copies of our magazine and none of anybody else's. Price £2.95 + £1.00 postage & packing (post free to PA members)

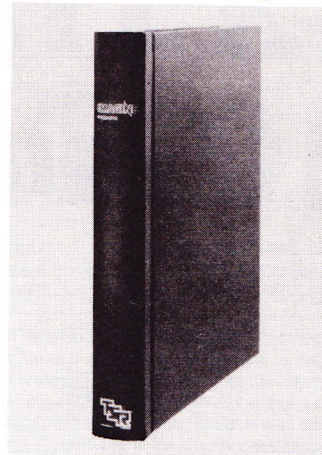

Send this coupon off today!

Please help me keep my IMAGINE magazines out of the hands of my kid brother/auntie Beattie/players.

Send me binders, at £2.95 + postage & packing each.

I enclose payment of

(PA members - pay no postage! Please quote your membership number)

Name

Address

Send to: TSR UK Ltd, The Mill, Rathmore Road, CAMBRIDGE CB1 4AD.

CRASIMOFF'S WORLD POSTAL GAME

Crasimoff's World is a fantasy game of exploration and adventure. As a player you assume the role of chieftain in a band of brave adventurers set on gaining knowledge and power. You must create a party of nine fellow travellers, from three character classes (fighter, mage and priest) to assist your chieftain.

Your party will set out from a small town, knowing nothing about the world apart from a few rumours. As you travel you will learn more about the land and its secrets, encountering other parties, races and creatures. There are tokens detailing magic items, spells, creatures, gods, money and many more things that you will discover later in the game.

'KJC Games has been running Crasimoff's World for over a year now, and the effort the gamesmaster puts into each turn never ceases to amaze me. Most players find themselves offered a different scenario each turn, or find that a new twist has happened to an existing adventure.'

as reviewed in

A WHITE DWARF N° 37

If you wish to enrol in Crasimoff's world send a £5 cheque/P.O. payable to K.J.C. Games. For this you will receive a rulebook, set up material, and the first four rounds. Future rounds are £1.25 each. Copies of the White Dwarf review are available free of charge from K.J.C. Games.

Send to: K.J.C. Games, 5 Vicarage Avenue, Cleveleys, LANCASHIRE FY5 2BD.

GALAXY

MAIDSTONE

DUNGEONS & DRAGONS
MINIATURE FIGURES
MODULES
TRAVELLER
RUNEQUEST

Large range of Fantasy & Wargames

Also

COMPUTER HARDWARE

Atari, Vic, Dragon, Texas

COMPUTER SOFTWARE

Vic, BBC, Spectrum, ZX81, Atari, Texas, Dragon

Plus Atari and Mattel,
VCS units and Imagic,
Parker & Activision
Cartridges

GALAXY

60 High Street,
Maidstone, KENT. (0622) 682575

Games

FOR WAR, FANTASY AND SCIENCE-FICTION GAMING

50-54 Manchester St.,
Liverpool L1 6ER.
Tel: 051 236 2605

Unit 20, Merrion Centre,
Leeds 2.
Tel: 0532 456376

63 Allerton Rd.,
Liverpool L18
Tel: 051 722 9022

MAIL ORDER
85-87 Victoria St.,
Liverpool L1 6DG.
Tel: 051 227 1505

TRADE
89 Victoria St.,
Liverpool L1 6DG
Tel: 051 236 2605

CHIVALRY & SORCERY 2nd EDITION

One of the original RPG's C & S is an historically based medieval role playing system. This new edition combines the details for which C & S was always justifiably famous, with new levels of rules clarity and organisation C & S 2 is a boxed three volume set at £12.95.

PRIVATEERS & GENTLEMEN

Naval role-playing game set in the years 1750-1820. Includes Hearts of Oak rules for naval battles with model ships. Three books, charts, tables, etc. Boxed £10.95.

DAREDEVILS ADVENTURES

A book of three separate adventures for the popular DAREDEVILS RPG. International adventures to test the sangfroid of any opponent of villainy. Complete with maps, characters etc. £3.50.

15mm SPACE OPERA FIGURES

The first four releases of a fine range of SF 15 mm miniatures are now available. Supplied in packets of 5 different figures, they combine quality design with sensible prices 55p per packet.

SOH1 HUMAN ADVENTURERS SOA1 ALIEN ADVENTURERS
SOH2 HUMAN ADVENTURERS SOA2 ALIEN ADVENTURERS

ROLE-PLAYING GAMES

CHIVALRY & SORCERY Second Edition

| | |
|--|--------|
| Chivalry & Sorcery 3 volume boxed set | £12.95 |
| C & S Sourcebook 2 supplementary material | £4.50 |
| Swords & Sorcerers. C & S supplementary material | £4.95 |
| Birame & Galley C & S naval combat | £7.45 |
| Castle Plans 25 mm scale castle floor plans | £2.95 |
| Fortification Plans 25 mm floor plans | £2.95 |
| Homes & Hovels 25 mm cut-out medieval buildings | £3.25 |
| Towers for Tyrants 25 mm cut-out medieval keep | £3.95 |
| AFTERMATH - post holocaust rpg. boxed | £12.50 |
| Into the Ruins. Aftermath scenario book | £3.75 |
| Operation Morpheus. Aftermath scenario book | £4.95 |
| DAREDEVILS rpg set in the 1930's. | |
| Boxed set rulebook, scenarios, ref's screen | £9.50 |
| Daredevils Adventures, book of three complete adventures | £3.50 |
| GANGSTER - criminal underworld role-playing | |
| Boxed set rules, charts etc | £7.95 |
| BUNNIES & BURROWS - rabbit role-playing | £3.95 |

| | |
|---|-------|
| VILLAINS & VIGILANTES 2nd Edition - Boxed set | £7.95 |
| 2nd Edition rulebook only | £3.95 |
| Crisis at Crusader Citadel - intro adventure | £3.25 |
| Death Duel with the Destroyers - V & V adventure | £3.25 |
| Island of Dr. Apocalypse - V & V Adventure | £3.25 |
| FORCE - V & V adventure | £3.25 |
| Organisations Unlimited V & V NPC's and their | |
| organisations | £3.25 |
| WILD WEST western role playing | |
| Boxed set rules, maps, charts etc | £8.95 |
| Trouble on Windows Peak. Wild West scenario pack | £2.75 |
| BUSHIDO Detailed rpg set in the Land of Nippon | |
| Boxed set, rule books, maps, charts, tables etc | £9.95 |
| Valley of the Mists Bushido Scenario pack | £3.25 |
| LAND OF THE RISING SUN - Samurai period Japan rpg | |
| Boxed set, rules, charts etc | £9.95 |
| MERC modern mercenary rpg, skirmish wargame | |
| Boxed set, rules, plastic overlay, charts etc | £9.50 |

THE SPACE OPERA ROLE-PLAYING SYSTEM

| | |
|--|-------|
| Space Opera: boxed set with rules, charts etc | £9.95 |
| Martigan Belt: Scenano pack | £3.25 |
| Alien Base: Scenano pack | £3.25 |
| Probe NOG B436: Scenano pack | £3.25 |
| Vault of the Nict Quoyon: Scenano pack | £3.25 |
| Incedus 3: Scenano pack | £3.25 |
| Rowson II: Scenano pack | £3.25 |
| Fasolt in Peril: Scenano pack | £2.75 |
| Star Sector Atlas 1: planets in the Terran Sector | £3.95 |
| Star Sector Atlas 2: the Mercantile League | £3.95 |
| Star Sector Atlas 11: the Confed System Alliance | £3.95 |
| Outworlds: Star Sector & scenario ideas | £3.95 |
| Ground Air Equipment: Sp Op heavy weapons | £3.25 |
| Seldon's Compendium of Starcraft: ship-plans | £3.75 |
| Space Marines: expanded ground combat rules | £3.95 |
| The Space Opera System continues to expand. Available soon will be another fine adventure, OPERATION PEREGRINE. The task for the players is to smash a highly organised criminal syndicate. Full of fascinating and original NPC's & encounters. It's tough! | |

TUNNELS & TROLLS FANTASY GAMES SYSTEM

| | |
|-----------------------------------|-------|
| Rulebook (2nd edition) | £3.95 |
| Tunnels & Trolls. Boxed Set | £6.95 |
| Naked Doom Solo Dungeon | £2.25 |
| Sorcerer Solitaire Solo Dungeon | £2.25 |
| Sword for Hire Solo Dungeon | £2.50 |
| Labyrinth Solo Dungeon | £2.25 |
| Buffalo Castle Solo Dungeon | £2.25 |
| City of Terror Solo Adventure | £3.95 |
| Beyond the Silvered Pane Solo D | £3.00 |
| Arena of Khazan Solo Adventure | £2.50 |
| Weirdworld Solo Dungeon | £2.25 |
| Overkill Solo Dungeon | £2.25 |
| Dungeon of the Bear Levels 1,2,3 | £3.50 |
| Uncle Uglics Underground | £1.50 |
| Circle of Ice Solo Adventure | 75p |
| Abyss Solo Adventure | 75p |
| Goblin Lake Solo Adventure | 75p |
| Catacombs of the Bear Cult 1 | £3.00 |
| Sea of Mystery Solo Adventure | £3.00 |
| Grimtooth's Traps Game aid | £3.75 |
| Deathtrap Equalizer Solo Dungeon | £3.30 |
| Blue Frog Tavern Solo Adventure | £2.50 |
| Misty Wood Solo Adventure | £2.50 |
| City Book Aid for all FRP systems | £7.50 |
| Sorcerer's Apprentice Magazine | £1.75 |
| Grimtooth's Top Game and Vol 2 | £3.75 |

NICE DICE PRICE!

| | |
|------------------------------------|-------|
| Standard polyset 6 dice | £1.20 |
| Or with inked numerals | £1.30 |
| Deluxe polyset with inked numerals | £1.30 |
| Fireball polyset | £1.50 |
| Or with inked numerals | £1.75 |
| Transparent Gem polyset | £1.95 |
| Or with inked numerals | £2.25 |
| Five assorted colour D6 | 40p |
| 30 sided dice | 70p |
| 30 sided dice inked | 80p |

COMING SOON - NICKEL & COPPER PLATED DICE

Fire & Movement Issue 34: Attack in the Ardennes; Rockets Red Glare; Ancient War-gaming (WRG Rules); Computer Games.

The Space Gamer Issue 64: Western scenario; Star Trek; Ogre; Interviews; news; reviews

*Both are £1.75 each per issue
*Six issue sub (inc. p&p) £10.50
*Back issues available.



WHY NOT ORDER BY TELEPHONE USING ACCESS OR BARCLAYCARD save the trouble of sending a letter and cheque.

WE PREFER THIS METHOD. We can try to answer any queries and you will also be sure you are getting exactly what you want and sooner normally be return of post.
P&P Order value over £6.00 Free
Order value up to £6.00 Add 25p

OVERSEAS TRADE ORDERS WELCOME

FGU BOARDGAMES (BG) & RULES (R)

| | |
|--------------------------------------|--------|
| Diadem: Science Fiction BG | £13.95 |
| Lords & Wizards: Fantasy BG | £9.95 |
| Colony Delta: Science Fiction BG | £7.95 |
| Oregon Trail: BG. Good solo | £9.95 |
| Star Explorer: BG Excellent solo | £9.95 |
| Archworld: Rules for fantasy battles | £3.25 |
| Galactic Conquest: SF RPG rules | £2.25 |
| Odyssey: History based fantasy rpg | £2.95 |
| Royal Armies of the Hyborean Age: R | £3.25 |
| Starships & Spacemen: SF RPG | £3.95 |

STANDARD GAMES & PUBLICATIONS

| | |
|--|--------|
| City Havoc - medieval skirmish game | £9.95 |
| City of Sorcerers - fantasy boardgame | £9.95 |
| Starship Captain - SF boardgame | £12.95 |
| The Village - extra map for Cry Havoc | £2.85 |
| The Crossroads - as above | £2.85 |
| The Forest - new map for Cry Havoc | £2.85 |
| Dungeon Floor Plan - role playing aid | £2.50 |
| Dungeon Accessory Pad as above | £2.50 |
| Felt hex - cloth playing surface; blue, sand or green. All with printed hex grid | £12.95 |
| Clear Plastic Hex Sheet - overlay | £1.80 |

TRAVELLER

| | |
|---------------------------------|------------|
| Starter Edition Traveller | £7.95 |
| Boxed Set | £5.95 |
| De Luxe Boxed Set | £8.95 |
| Book 4: Mercenary | £2.95 |
| Book 5: High Guard | £2.95 |
| Official Traveller Supplements | each £2.50 |
| Official Traveller Adventures | each £2.50 |
| Official Traveller Double Advs. | each £2.50 |

TRAVELLER COMPATIBLE GAMES

| | |
|-------------------------|--------|
| Mayday | £6.95 |
| Snapshot | £6.95 |
| Azchanti High Lightning | £17.95 |
| Invasion Earth | £9.95 |
| Fifth Frontier War | £11.95 |
| Striker | £10.95 |

RUNEQUEST

| | |
|----------------------------------|--------|
| Boxed Set | £8.95 |
| Rules only | £6.95 |
| Cults of Prax | £6.95 |
| Trollpack | £14.95 |
| Runequest Character Sheets | £1.99 |
| Questworld | £12.95 |
| Apple Lane | £2.95 |
| Borderlands | £12.95 |
| Soloquest 1 | £4.95 |
| Soloquest 11: Scorpion Hall | £4.95 |
| Soloquest 111: Snow King's Bride | £4.95 |
| Pavis | £14.95 |
| Runequest Rules in Hardcover | £10.95 |

STEVE JACKSON GAMES

| | |
|--|-------|
| Car Wars: motorised murder and mayhem | £3.95 |
| Car Wars Exp Kit 1: more mm & m | £2.25 |
| CW Exp Kit 2: more & more mm & m | £2.25 |
| Sunday Drivers: CW rp adventure | £3.95 |
| Truck Stop: CW big rig supplement | £3.95 |
| Autoduel Quarterly Issue 1: Car wars mag | £1.75 |
| Ogre: classic game of super tanks | £3.95 |
| GvE: expands upon the Ogre idea | £3.95 |
| Battlesuit: power armoured infantry | £3.95 |
| Illuminati: the stealthy alternative | £4.25 |
| Illuminati Expansions 1 & 2: each | £4.25 |
| Necromancer: wizard combat | £3.95 |
| CB Heroes: latest releases | £1.99 |

TSR UK Ltd.

| | |
|--|-------|
| D & D Basic Set rules, dice, adventure | £8.95 |
| D & D Expert Set, rules dice, adv | £8.95 |
| D & D Basic Rules only | £3.95 |
| D & D Expert Rules only | £2.50 |
| A & D Character Records sheets | £9.95 |
| A & D Dungeon Masters Guide | £9.95 |
| A & D Players Handbook | £8.95 |
| A & D Monster Manual | £8.95 |
| A & D Deities + Demigods | £8.95 |
| A & D Fiend Folio | £8.95 |
| A & D Dungeon Masters Screen | £4.95 |
| A & D Character Record sheets | £3.50 |
| A & D Player Character Folder | £3.50 |
| A & D NPC Character Record sheets | £3.50 |
| A & D DM's Adventure Log | £3.50 |
| Rogues Gallery NPC stats | £3.50 |
| World of Greyhawk | £6.95 |
| "Amazing" magazine | 75p |

MODULES - BASIC D & D

| | |
|----------------|------------|
| B1; B4 | each £3.50 |
| B2; B3 | each £3.95 |
| M1 Solo Module | each £4.50 |

MODULES - EXPERT D & D

| | |
|----------------|------------|
| X1; X2; X3; X4 | each £3.95 |
|----------------|------------|

MODULES - A & D

| | |
|------------------------------------|------------|
| S2 | £2.95 |
| A1; A3; C2; D3; S1; T1 | each £3.50 |
| A2; A4; I1; I2; N1; | each £3.95 |
| U2; L1; UK1; EX1; EX2 | each £3.95 |
| C1; D1-2; G1-3; Q1; WG4; I3; I4 | each £4.50 |
| S3; S4 | each £5.50 |
| Dragon Magazine | £2.50 |
| Gamma World | £8.50 |
| G W Modules: GW1; GW2 | each £2.95 |
| G W Mini Module & Referees' Screen | £2.95 |
| Boot Hill | £8.50 |
| B H Modules: BH1; BH2; BH3 | each £2.95 |
| B H Mini Module & Referees' Screen | £2.95 |
| Top Secret (including Module 1) | £8.50 |
| T S Modules: TS2; TS3; TS4 | each £2.95 |
| TS Mini Module & Referees' Screen | £2.95 |
| Gangbusters | £8.50 |
| G B Modules: GB1; GB2 | each £2.95 |
| Starfrontiers (inc. Module 0) | £8.95 |
| S F Modules: SF1 SF2 | each £3.95 |
| S F Mini Module & Referees' Screen | £2.95 |
| Dawn Patrol | £8.50 |
| Fantasy Forest | 4.95 |
| Endless Quest Books | each 95p |
| Ares (S F/Fantasy mag + game) | £3.95 |

MAN, MYTH & MAGIC

| | |
|------------------------------------|--------|
| Boxed Set with introductory module | £14.95 |
| Death to Setanta | £3.95 |
| Kingdom of the Sidhe | £3.95 |
| Newgrange Reactivated | £3.95 |
| The Glastonbury Labyrinth | £3.95 |
| Ascent to Hell | £3.95 |

WILDERLANDS CAMPAIGN from JUDGES GUILD

| | |
|-----------------------------------|-------|
| City State of the World Emperor | £8.95 |
| City State of Invincible Overlord | £6.50 |
| Wraith Overlord | £8.95 |
| Glory Hole Dwarven Mine | £2.99 |
| Wildierlands of High Fantasy | £6.50 |
| Wildierlands of Fantastic Reaches | £6.50 |
| Fantastic Wildierland Beyond | £6.50 |
| Wildierlands of the Magic Realm | £6.50 |

STARFLEET BATTLES

| | |
|-------------------------|--------|
| Boxed Game | £14.95 |
| Expansion Module 1 | £4.95 |
| Expansion Module 2 | £5.95 |
| Expansion Module 3 | £5.95 |
| Federation Space | £13.95 |
| Battle Damage: Code Red | £4.50 |

AVALON HILL fantasy/sf boardgames

| | |
|-----------------------|--------|
| Alpha Omega | £10.45 |
| Arnoeba Wars | £11.95 |
| Dragon Hunt | £11.95 |
| Dune | £11.95 |
| Freedom in the Galaxy | £14.75 |
| Magic Realm | £11.95 |
| Starship Troopers | £11.95 |
| Titan | £11.95 |
| UFO | £4.95 |
| Wizard's Quest | £11.95 |
| Wizard's | £10.45 |
| Samurai | £10.45 |
| Circus Maximus | £7.95 |
| Gladiator | £7.95 |
| Down with the King | £8.45 |
| Gunslinger | £14.95 |
| Machiavelli | £10.45 |

COMPUTER GAMES FROM AVALON HILL

| | |
|--|------------|
| Shootout (at OK Galaxy): A32 P8 A116 T16 TC16 | £14.95 |
| Moon Patrol: A116 | £18.95 |
| Andromeda Conquest: T16 A16 P16 A32 | each £4.50 |
| Lords of Karma: T48 A32 P32 | £13.45 |
| Conflict 2500: T16 A16 P16 A32 | £11.95 |
| Empire of the Overmind: T48 A48 A140 | £21.95 |
| Voyager 1: TC16 T16 A32 A32 P32 | £14.95 |
| Galaxy: T16 A16 P16 A116 | £14.95 |
| Space Station Zulu: A132 | £14.95 |
| Gypsy: A116 | £15.95 |
| Telengard: + A148 | £18.95 |
| Vorrik: + A148 | £18.95 |
| GFS Sorceress: A140 A48 T48 | £21.95 |
| KEY - = on cassette; + = on disc; P = Pet A = Apple 11; At = Atari; T = TRS 80; TC = TRS Colour; numbers = memory required in K. | |



MAIL ORDER SERVICE

HERE'S WHAT WE OFFER:

- A VERY FAST TURN ROUND
- POST PAID ON ORDERS OVER £6.00
- INFORMATIVE FREE NEWSLETTER
- SPECIAL OFFERS
- TELEPHONE ORDERS BY CREDIT CARD

Details of how to order are given elsewhere on this page. Why not give us a try - you probably deserve a pleasant surprise.



TRADE ENQUIRIES
MOST ITEMS ON THIS PAGE ARE
AVAILABLE TO THE TRADE
SEND FOR FULL LISTS

DRAGONQUEST ROLE PLAYING SYSTEM

| | |
|---------------------|-------|
| Boxed Set | £8.50 |
| Hardback Book | £7.50 |
| Enchanted Wood | £3.95 |
| Frontiers of Alusia | £2.95 |
| Palace of Ontocle | £2.95 |

SPECIAL PA OFFERS

Please note that the following offers are available **only** to members of the D&D® Players Association. Details of the PA are on p33 of this magazine.

BARGAIN BASEMENT

The Bargain Basement (lair of the infamous Karen) is the place where we consign all the stock which, for some reason or other, can no longer be sold as 'perfect'. The degree of imperfection varies from a missing shrink-wrap to the lack of a page in a module, for example. The items all have two things in common, however, they are all on sale at amazingly reduced prices and none of them is rubbish.

PA members can obtain an up-to-date list of available Bargain Basement items by sending an SAE to Bargain Basement at the address given below. Don't forget to quote your PA membership number.

RPGA™ Module 1 — RAHASIA

A 16-page D&D module designed for 5-8 characters of levels 1-2. Price £2.00, post free.

Rahasia the elven maid faces a fate worse than death at the hands of an evil human, Rahib, who has taken over the Temple of the Sacred Black Rock, cursed its elven servants, and lured Rahasia's father and her betrothed into his clutches. You are Rahasia's last hope. Can you brave the Temple's perils and mete out justice to Rahib?

'R SERIES' MODULES

The 'R series' AD&D™ adventure modules are produced by the RPGA™ organisation in the USA and are available in the UK only to PA members. Each module was designed for use in a GEN CON® tournament and is suitable for normal campaign play as well as including extra details and pre-rolled characters for tournament-style use.

R1 — TO THE AID OF FALX

A 16-page module designed for 6 characters of levels 5-9. Price £1.50, post free.

Falx the silver dragon, much to his chagrin, needs some human aid. The dark powers that control a nearby set of tunnels have stolen five potions of silver dragon control! Can the adventurers find the potions before nightfall?

R2 — THE INVESTIGATION OF HYDELL

A 32-page module designed for 5 characters of 5th level. Price £2.00, post free.

Slinks are obedient, semi-human slaves and are apparently content with their lot. They are protected by law, owned by the wealthy and approved of by the church authorities. Can you sneak into the old ruins to find out who or what slinks really are and where they come from?

R3 — EGG OF THE PHOENIX

A 32-page module designed for 5-8 characters of level 5-9. Price £2.00, post free.

In the lonely town of Northending, the council has called paladin Athelstan to their aid. The fabulous artifact known as the Egg of the Phoenix has been stolen by evil beings.

'MILL DAYS'

The next Mill Day is on Saturday, 10th September; anyone thinking of attending the following month's session should note that it will take place on October 22nd, not on the 29th as previously announced.

Mill Days are open to PA members only. There is no fee but places must be booked in advance. For details, write to 'Players Association Mill Days' at the address below, enclosing an SAE.

PA PINS

These are half-inch diameter brushed steel badges carrying our Dragon's-Head logo. They will double as a lapel badge or tie-pin and will discreetly identify you as a player and PA member. Price £0.95 each, post free.

PA T-SHIRTS

White cotton T-shirts with full-colour design of a dragon towering over the D&D symbol. Available in S, M and L (please state size when ordering). £3.50 each, post free.

PAN BACK ISSUES

It always happens. No sooner does a magazine come to an end than its back issues become collector's items. PA members can obtain back issues of PANs 1-12 for £0.50 each or £5.00 for a set of 12, post free.

Offers are open to PA members only. Orders to: PA Special Offers, TSR UK Ltd, The Mill, Rathmore Road, CAMBRIDGE CB1 4AD.

Remember to include your PA membership number when ordering. All offers subject to availability.

D&D® PLAYERS ASSOCIATION NEWS



THE NEWSLETTER
OF THE BRITISH
DUNGEONS & DRAGONS®
PLAYERS ASSOCIATION

PAN PIPINGS

Revolutions....

There comes a point in transfers of power by constitutional means, when the talking has to stop and the shooting begin. Such a time has come at TSR UK.

In common with all previous holders of the office of PAN Editor, Graeme Morris has stepped down and gone to greater, more lasting fame, as an ex-editor.

For too long the legitimate aspirations of the rest of the staff — breathing without asking permission, lunch hours etc — went without answer from this monstrous tyrant. The Day of the Revolución dawned.

In his acceptance address to the assembled staff (and his military advisers from IMAGINE™ magazine) El Nuevo Presidente said: 'I shall, of course, do my humble best in the role of Editor. Dissidents will be freed when the time is right, and when the political climate settles down elections may be held on a limited basis. My people, things will get better! One day there will be bread and T2!'

Secretary of State Thomson later denied all knowledge of the presence of forces from the rest of the magazine and claimed that the Revolución — sorry — 'Legitimate Transfer of Constitutional Power' was a purely internal affair, but that aid could be made available at a later date for policing operations.

....And Revisions

Among other items found in the rubble of the Editorial Palace were two things of considerable interest to all D&D players and members of the PA.

The first of these was a mysterious document covered in illiterate scrawl — obviously the work of GM. When deciphered it proved to be some future plans for the Players Association.

The PA Newsletter will remain as a section in IMAGINE magazine. The re-

sources of time, manpower and material do not allow PAN to re-emerge as a separate entity. However, a news broadsheet will be printed quarterly and sent to PA members. If you are a PA member, the first should be in your hands within a month or so. Some of the material will be familiar — Bargain Basement, PA offers, Mill Day details etc — but the rest will be new and unique to the broadsheet — a separate editorial, smaller pieces on specialised aspects of the game and some form of competition, with pre-release copies of modules as prizes.

The second item was the new revised D&D® Basic Set, ('Oh no!' I hear you cry, 'not again!'). This isn't really a revision of the rules as such, although some details have been tightened up considerably, but a revision in presentation and emphasis. The Basic Set now contains two books, a Players Manual and a Dungeon Masters Rulebook, which contain all the information necessary to start playing the game from scratch. Of interest to established players will be the details of what is to come for the D&D game. The Expert set is to be revised as well, and the Companion Set will eventually be published, covering character progression from 15th to 25th levels. Beyond the Companion Set is the Masters Set, detailing the game up to the 36th level. The new sets will be advertised when they are available, so please do not order them until then.

And Finally, The Truth....

Graeme has been shifted into production of full-scale 32 page modules. Those of you who have played in any of the AD&D™ Open Competitions at Games-Fair will know that his adventures will be worth the wait. GM will continue to argue with me over Dispel Confusion answers, and write mini-modules for the magazine.

Now, I wonder how I get control of the editorial column at the front of the magazine....

Mike Brunton



DISPEL CONFUSION

Dispel Confusion is a question and answer column intended to help hobby gamers overcome problems they have had with game rules.

At present, we can only help with games produced by TSR; while our answers may not be fully 'official', we have contact with the designers themselves. In future, we hope to cover games other than TSR products, by getting answers from those who make and design them.

*But we always need questions - so send your queries to: **Players Association (Dispel Confusion), TSR UK Ltd, The Mill, Rathmore Road, CAMBRIDGE CB1 4AD.***

DUNGEONS & DRAGONS® and ADVANCED DUNGEONS & DRAGONS® games

Q. What is the meaning of 'standard' when referring to a monster's magic resistance? (Advanced)

A. Magic resistance has three types of rating for monsters:

'Standard' means that the monster is entitled to all relevant saving throws against whatever spells are being used against it, in exactly the same way that characters are allowed a saving throw against spells.

A percentage rating is the chance of a spell cast against the monster failing outright. This is in addition to any saving throw that the recipient of the spell is entitled to. The percentage

chance given is for a spell cast by an 11th level magic-user. The chance is modified by 5% for every level difference of the caster — eg a 50% magic resistance bonus for a spell cast by a 1st level magic-user. This means that 0% magic resistance is really quite formidable.

'Nil' magic resistance indicates that the unfortunate monster is not even entitled to a normal saving throw.

Q. When a cleric turns undead creatures in a confined space such as a room, what do the undead actually do? For how long are the undead turned? (Basic/Advanced)

A. Undead monsters successfully turned by a cleric normally flee as far as possible. In a confined space the undead will cower in a corner as far away as possible from the cleric who turned them.

The duration of the turning is different in each game. In the Basic game undead are turned away for 1-10 rounds, and in the Advanced game the turning lasts 3-12 rounds. At the end of this period the undead monsters return (or stop cowering) but are subject to further turning attempts by the cleric.

Q. The rules state that daggers have a fire rate of two per round. Is this applicable to daggers in hand-to-hand fighting or not? (Advanced)

A. The use of the term 'fire rate' makes it clear that this applies only to

daggers used as missile weapons — assuming that sufficient daggers are available. A dagger can make multiple melee attacks per round, once a fighter who wields it is of sufficiently high level.

Q. In the **Players Handbook** it states that monks attack on the same combat table as thieves, yet in the DMG (p74) it states that monks attack on the same combat table as clerics and druids. Which is correct? (Advanced)

A. The **Dungeon Masters Guide** always supercedes the **Players Handbook** in cases where the rules appear to be inconsistent.

Q. Are drow elves psionic or not? The FIEND FOLIOT™ Tome and the G and D series modules list this ability as 'unknown'. (Advanced)

A. Whether drow elves are psionic or not is up to the DM in any particular campaign. Drow are already a singularly powerful and flexible group of monsters for adventurers to deal with, and this should be borne in mind when the DM decides on the matter of psionics.

Life for characters would not be as rich if all such mysteries were completely explained.

Q. Do druids have the same wisdom bonus for spells as clerics? (Advanced)

A. As a sub class of cleric, druids do indeed get the wisdom bonus for

TURNBULL TALKING

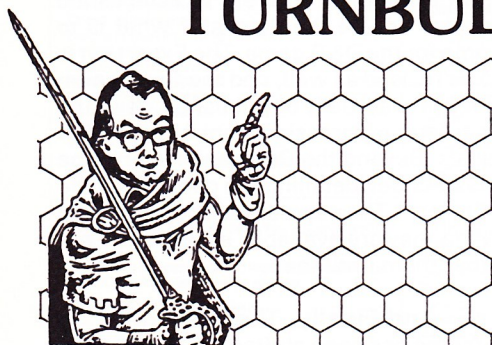

Thanks to the many good readers who not only saw my point about the 'pub game' (issue 3) but wrote in with multi-legged pub names (no thanks to he who wrote saying the piece was the depths of banality, since he obviously missed the point — please engage eyes and brain before putting biro into gear).

By a long way, the clear maxilegger so far is 'The Light Brigade' spotted by Robin Allen. Over 3½ thousand legs in one pub is surely unbeatable *if* your house rules

allow this interpretation. I must now work out why mine don't, just in case Gary Gygax spots it first. Where is it? Well, why on earth should I tell?? Thanks, Robin.

Switching sharply to another topic, though I'm not going to pick up the gauntlet discreetly dropped by Kim Daniel in issue 5 (discreetly? Who am I kidding? I heard the clang two offices and a flight of stairs away!), I do share her regret that the adventure gaming hobby is in the main a male enterprise. At the moment, that is — I am not the only one to hope this will change.

There is no obvious reason why this should be so. Even if Kim's final contention is right — that females are better players than the fellows — that's all to the good in role-playing games which are cooperative rather than competitive. When Lord Chevasse (one of my newer characters, and a nice chap really) is faced

with gruesome death in Dave Tant's latest and most fiendish adventure, I want a good character nearby to drag him to safety. It matters nothing whether that character is run by male or female.

Certainly I have played in D&D® games with good female players and mediocre female players; there are a few really bad male players but I have not yet met a female in that category. The only female DM my characters have encountered is a pretty good DM, whereas male DMs can be good, bad or anywhere in between (in contrast, female drivers are either good or dire — there doesn't seem to be any middle ground).

Kim touches on wargames and has half a point here too. War is traditionally a male preoccupation (though Brunehild was allegedly a pretty aggressive cookie and Boadicea didn't spend much time at home minding the kids), hence wargaming is

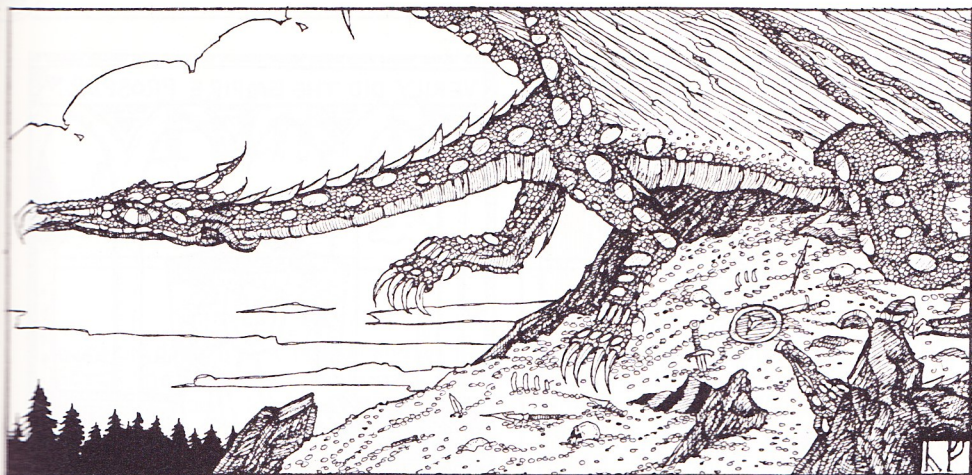

remembered spells. Paladins and Rangers do NOT get a bonus for any exceptional wisdom score when they become eligible to cast spells.

- Q. Are characters of chaotic alignment evil? (Basic)
- A. Alignment in the Basic game is handled in a more simple manner than in the Advanced game.

The rulebook states that chaotic behaviour is what would be termed 'evil' by contemporary society — paramount self interest, little concern for the welfare of others, acting upon spur-of-the-moment decisions etc — although much of this type of behaviour would have been quite acceptable to a medieval nobleman.

Chaotic characters need not necessarily commit 'evil' acts all the time in a D&D® game, but their unpredictability would mean that their behaviour was less than honourable for most of the time.

- Q. Are the number of hit points which can be cured by the psionic minor devotion cell adjustment the maximum which can be cured per day? (Advanced)
- A. Our interpretation of this discipline is that the number of hit points cured is the maximum which can be cured per day by any particular psionic character — thus a 4th level cleric could cure 20 hit points per day using this discipline, assuming that the strength point cost could be met. This use of the discipline does not disallow the curing of disease by the same method.
- Q. Can an elf be a split-class assassin? (Advanced)
- A. No. The allowable split classes for an elf are defined on page 16 of the **Players Handbook**, and an assassin combination is not allowed. The concepts inherent in assassination are not really compatible with elves.

Graeme Morris & Mike Brunton



male-dominated. But how does this square with the observation that war-gamers are generally pacific people who would shun real war but welcome intellectual challenges over a game board? On the other hand, there aren't any female chess grandmasters, as far as I am aware.

In the end, I believe this phenomenon is more the product of habit than any other factor. There is nothing in D&D or in many other role-playing games which makes them male preserves. Indeed male players sometimes run female characters and vice versa. I am not convinced that the same is true for certain types of role-playing game; the espionage role-playing game, such as the TOP SECRET™ game, will probably appeal less to the fair sex, *pace* Modesty Blaise and Emma Peel, and I guess the same is true of the GANG-BUSTERS™ game (who, male or female, wants to role play a moll?).

Simply, I believe that fewer females play games than males. Full stop. This has nothing to do with sex-typing, the liberation of the female or male porcine chauvinism. It's just a fact, so far as my own observation goes. Similarly I guess that male drivers and female primary school teachers are in the respective majority.

It's encouraging to see some change already. In the three years of GamesFair the number of female delegates has quadrupled (and that's not just 1 to 4!) and there has been a girl in each final of the AD&D™ Open Championship (by skill, not because we fixed it that way). Here's hoping for further change — after all, both 'sides' will gain in enjoyment of the hobby.

Don Turnbull

(The reason fewer women play games is because we spend so much time attending to men! Proof: I'm typing up Don's blinkered observations. - KD)

PA MEMBERSHIP

The PA is a club for all players of role playing games particularly the D&D® and AD&D™ games. Since it was founded in 1981, the PA has become the country's largest D&D club, and now has this 4-page section in IMAGINE™ magazine. The benefits of membership include:

- * Free badge, sticker and personalised 'credit-card style' membership card.
- * Special offers available only to PA members, including the 'R' series of modules and Bargain Basement — your chance to buy damaged-but-usable stock at greatly reduced prices. Fuller details of the special offers are given on page 31.
- * Free postage and packing on mail orders from TSR UK Ltd for UK and BFPO members.
- * Discounts on tickets for GamesFair hobby conventions.
- * Listings of PA members in your area (send SAE).

Membership of the PA costs £2.50 per year for new UK or BFPO members (£2.00 for renewals) and £5.00 (or US \$10) for overseas members. All you have to do is fill in this coupon and send it to:

PA Memberships, TSR UK Ltd, The Mill, Rathmore Rd, Cambridge CB1 4AD, England

together with a cheque or postal order made payable to TSR UK Ltd.

- Please enrol me as a new member of the Players Association. I enclose a cheque/PO for £2.50 (overseas £5.00 or US \$10).
- Please renew my membership of the PA. I enclose a cheque/PO for £2.00 (overseas £5.00 or US \$10).
My PA number is.....

Name (Mr/Mrs/Miss/Ms)

Address.....

.....
.....

I do/do not* wish my name and address to be available to other members.
(* delete as appropriate)

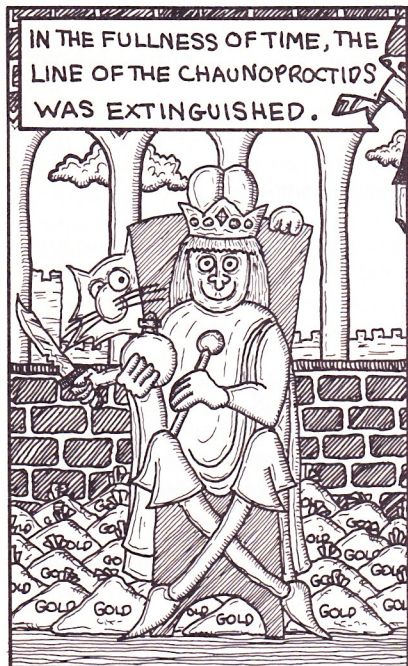
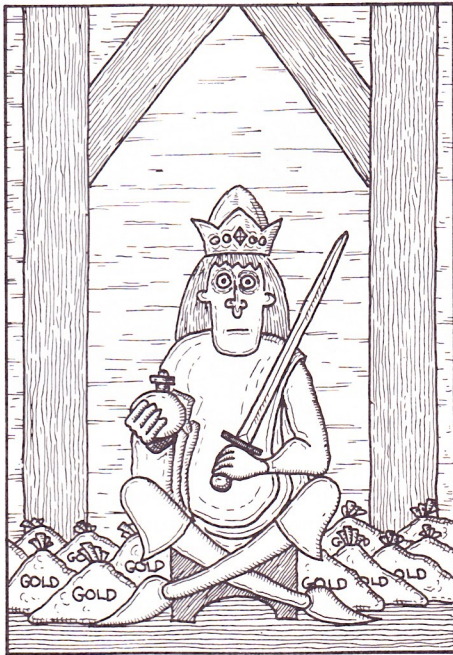

RUBIC OF MOGGEDON

IMPRISONED IN THE TOWER OF TERROR BY HIS MORTAL Foe THE BLACK NECROMANCER, RUBIC FACES TORTURES TOO HIDEOUS TO CONTEMPLATE.

HISTORICAL FOOTNOTE THE FIRST

AEONS AGONE, 'ERE MIGHTY ERLIK SAT HIS EBON THRONE, ALF, FIRST OF THE CHAUNOPROCTIDS, STABLISHED A BROAD REALM BETWIXT THE MOUNTAINS AND THE SEA, AND BUILDED HIM A GREAT CITY FROM WHICH TO BEAR RULE OVER THE BARBARIANS.....

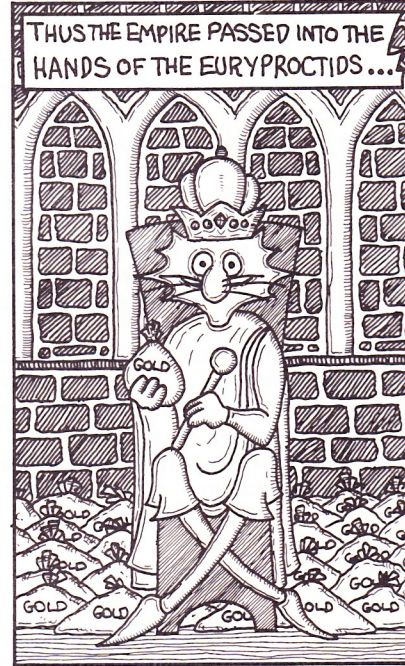

AND THERE WAS GREAT REJOICING!

BUT THIS IS THE THIRD MONTHLY ANNUAL TAX ASSESSMENT THIS WEEK!

LOCAL TAXATION CENTRE

NEXT!

QUEUE THIS SIDE



CLAWBACK DEPARTMENT

CERTIFICATE OF PENURY

IS TO CERTIFY THAT THE HONORABLE MEMBER HAS BEEN OFFICIALLY DEEMED TO BE A MEMBER OF THE CLAWBACK DEPARTMENT AND AS SUCH IS ENTITLED TO ALL THE BENEFITS AND PRIVILEGES OF THE CLAWBACK DEPARTMENT.



GENERAL AUDITING DEPARTMENT

MERCY! 'T WAS BUT A SINGLE GOLD PIECE!

YOU MUST LEARN THAT TAX-AVOIDANCE NEVER PAYS!

Film Review

This month Colin Greenland takes a look at some of the latest films on the sci-fi/fantasy circuit: **Android**, **Something Wicked This Way Comes** and — of course — **Return of the Jedi**.

In the old days mad scientists always had labs at the tops of towers (really *must* have been mad — all those stairs to climb every time you forgot a test tube). After that, they worked in secret subterranean hideaways. Now they're back on high, in orbital space stations. Anything for a bit of privacy.

The year is 2036, the scene is Terraco Station ULC53, the mad scientist is Dr Daniel, played by Klaus Kinski, every bit as crazed and masterful for director Aaron Lipstadt as he ever was for Werner Herzog. The film is **Android** (New World, 15). Dr Daniel's Cassandra 1 Project, to make the perfect android, has officially been terminated since the robot revolt in Munich. But you know these mad scientists.... Nothing will stop Daniel now, not even interruption by three dangerous convicts on the run. In fact, he sees the surprise visit as a chance to steal the life-force of one of them to animate Cassandra.

Android is a neat little film, showing what can be done on a small budget with ingenuity and care. It is nothing new in SF cinema — even the plot-twists have been cribbed from other movies, particularly *Alien* and *Blade Runner*, though no acknowledgement is made to Ridley Scott. The original that Lipstadt does honour is Fritz Lang's *Metropolis*, which is in Station ULC53's video archive. Dr Daniel even looks just like the villainous Rotwang. But the star of *Android* is Don Opper as Max 404, the doctor's lonely assistant, who has never met a woman until the convicts arrive, and who dreads that when Cassandra is operational, he will be out of a job — and worse.

Walt Disney Productions introduce Ray Bradbury to the big screen in **Something Wicked This Way Comes** (Disney, PG). It is an obvious pairing: both partners have made a mint out of mining the heart of America — specifically the dreams and nightmares of boyhood in that friendly little old town in the mid-West. 'Sometimes a man can learn more from other men's dreams than he can from his own.' This is a faithful adaptation by the author, full of lines like that, rich with wisdom and sentiment and wholesome country goodness which is all a bit much for an ageing city cynic like me, though I remember being spellbound by Bradbury's tales too, when I were a lad.

Well, as usual, in Greentown, Illinois it is 1930 — October, to be exact, that most Bradburyan of months, and time for the

arrival of the 'Autumn People', by train, at dead of night, with all the gaudy and sinister paraphernalia of Dark's Pandemonium Carnival. Jonathan Pryce is nicely nasty as Mr Dark, the devil who brings real evil to Greentown, and especially into the lives of young Will Halloway and Jim Nightshade. His Carnival offers people instant escape from their humdrum lives — but at a price they were not bargaining for. Dark and his

incandescent in his fingers as he crumples it and casts it irrevocably away.

Oh, yes, and then there is **Return of the Jedi** (Fox, U). The pantomime continues. Hooray for the rebels! Boo for the Empire, now building another Death Star. Will they never learn? Is Han Solo still alive? How will he escape the sluglike clutches of Jabba the Hutt? Is Darth Vader really Skywalker, Snr? All is revealed, as neatly



SOMETHING WICKED THIS WAY COMES © 1983 Walt Disney Productions.
The Dust Witch (Pam Grier), the ethereal emissary of evil from a mysterious travelling carnival despatches a tarantula to find Will and Jim.

roustabouts 'destroy people by granting their dearest wishes' — neat, that. And in the transformations and fantasies of the story, special effects team Lee Dyer and Steve McEveety really go to the limit.

This is one for the SFX connoisseur, a visual feast. Oddly, among all the grand displays — the transdimensional carousel, the maddening Maze of Mirrors, the cataclysmic tornado — the scene which has gripped everybody's imagination, from Bradbury himself to the most jaded movie critic, is a little one. Dark corners Will's father in the town library and torments him with the vanished years. As he tears page after page from the book of Holloway's life, each lights up briefly,

as Shakespeare used to do it, in accordance with the master-plan of George Lucas, ably executed by director Richard Marquand. Much the tightest and most exciting of the trilogy, with excellent matte-work and modelling, though some of the superimposition is still a bit rough. You would think a series like *Star Wars*, fuelled by public adoration, coasting along on the hyperdrive of its own hyperboles, would get inexorably worse. It is not. It is getting better.

✍️ Colin Greenland

Colin Greenland will return to review more films in issue 8. Next month Dave Pringle strikes back with another selection of new book releases likely to be of interest adventure gamers.

CHAIN MAIL by Brian Creese

A new bi-monthly feature about the postal gaming hobby

DIPLOMACY

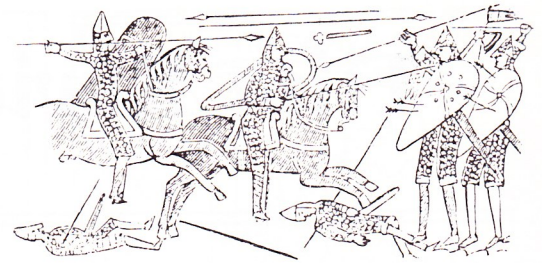

The whole hobby of postal gaming is based on the board game Diplomacy, so it seems natural to start my series on postal games with this game, the (postal) daddy of them all.

Like most good games, Diplomacy is essentially very simple. There are seven players, each representing a major European power at the turn of the century. The playing area is a map of Europe divided into *provinces*; typically there are five or six provinces to a country. Certain of these provinces are designated Supply Centres — and these are the provinces that count.

Considered as a War Game, Diplomacy is childishly simple. The object is to control over half the Supply Centres in Europe (18 out of 34). To do this you have armies and fleets which move one province at a time. Combat is simplicity itself, units can combine in an action, the greater combination wins forcing the loser to retreat his or her unit. There are certain strategic and tactical ideas which can be considered, but the game at this level is extremely straightforward.

The great achievement of Diplomacy is the concept of *...diplomacy*. Instead of playing in turns, all players submit 'orders' simultaneously. A deadline is set (say 20 minutes in a face-to-face game) and all orders must be given in at that time. Secondly you are encouraged, indeed you *have* to talk to the other players. Because you start as one of seven equal powers and aim to be bigger than the rest you will need the help of other players. They, similarly, will need your help. This help may be low-key — not attacking each other — or, more obviously, actually supporting each other's units in attacks. The 20 minutes will be spent negotiating with the other players, but as the moves are revealed together, *you do not know whether they are telling the truth*. When the orders are revealed the moment of truth arrives, and it is a rare game indeed in which the very first set of orders does not see a couple of pale faces and cries of 'stab!'.
Playing Diplomacy face-to-face is an exhausting business; after the first few hours (a typical game may last about 18 moves) the winner is likely to be the person with the greatest energy rather than of the highest creativity. Logistics can tend to be a problem, as the Triple Alliance squeezes into the loo to avoid the Russian who sits sulkily on the stairs. My first ever attempt at the game came to an

end when my great plans were overheard through the dining room hatch! Playing by post, however, allows deadlines several weeks apart giving as much time as you want for strategic planning, letters and phone calls. It really is an ideal game for playing by post since the game is improved by the longer deadlines, while the simultaneous revelation of orders is ideally catered for by the zine format; the basic game also needs virtually no change

orders, or if they arrive by the second post on deadline day rather than the first. There are also other zines which enjoy the devious aspect of the game and actively encourage imaginative coups. This is a controversial area. The world of postal Diplomacy *can* be an unscrupulous place. If you write a letter to B saying that you intend tearing C apart, don't be surprised if B photocopies your letter and sends it to C for you! There have been



to its rules for adaption to postal play. Indeed, all that is required of someone running postal Diplomacy is a fairly simple set of 'house rules' to cover eventualities such as orders posted before the deadline but being delayed.

Most postal zines provide opportunities to play Diplomacy. How, then, should you decide which one to play in? In my view Diplomacy is a game that requires a reasonably reliable progress but with sufficient time for the diplomatic aspect (letters, phone-calls etc). I like there to be about three weeks from receipt of the zine to the next deadline — any less and I tend not to bother writing the necessary letters and depend instead on a last minute phone call. I also dislike having to wait too long for the adjudication (turnround in Diplomacy parlance); otherwise I lose momentum — or in one game I'm playing, forget why I ordered the moves I did! Any regular, efficient zine is a good place to play the game.

One or two zines have set themselves up as being for the expert. These are characterised by very harsh GMing (the GM is the one who runs the game) and house rules. In these zines, expect no mercy if your pen slips when writing

many famous coups in the past, usually involving impersonating either another player or the GM, or sending out fake copies of the zine you are playing in. These things *do* happen, though not as often as you may expect at first.

Avid games-players should be warned that once you have played Diplomacy, no game is the same again. The essence of the game is that the weaker powers should always band together against the stronger ones, thus redressing the balance; there are few games in which this principle cannot be applied, and committed Diplomacy players can always be spotted at the *Monopoly* table, pointing out to the holder of Mayfair the advantages of an alliance against the holder of the Old Kent Road....

Diplomacy is an ideal start to postal gaming. You can play in almost any zine, the mechanics are very simple and one game does not take up a vast amount of time. A typical game will take between 18 months and two years and can provide you with any amount of joy and probably horror as well. Truly, Diplomacy must be considered one of *the* great games of our time.

Brian Creese

STEVE JACKSON

The best name in the game

TRUCK STOP — Here it is — Car Wars with Juggernauts!

Movement and combat rules for the huge, menacing 18-wheeler big rigs. Components include counters, rules and a map of a typical fortified truck stop in the America of 2033. You will need the original Car Wars rules to play.

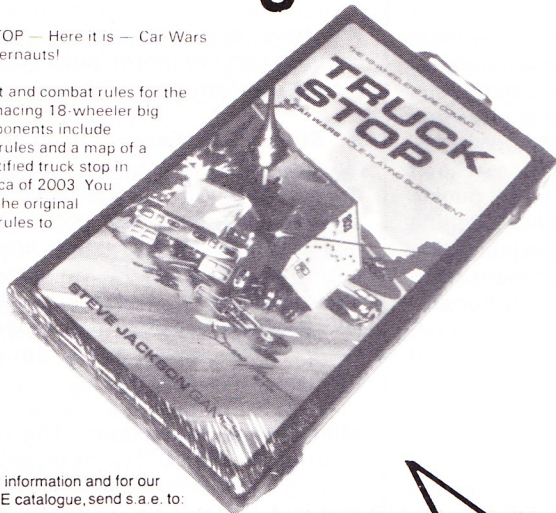

For further information and for our latest FREE catalogue, send s.a.e. to:

FLYING BUFFALO

P.O. Box 100, Bath Street, Walsall, W. Midlands.



chronicle

MINIATURES

UNIT 14, ENGINEER PARK, FACTORY ROAD, SANDYCROFT, CLWYD CH5 2QD. Tel: (0244) 537012

ADVENTURERS

| | | |
|-------|---------------------------------|-----|
| CF. 6 | DWARF FIGHTER w. TWO HANDED AXE | 35p |
| CF. 7 | FIGHTER w. TWO HANDED AXE | 35p |
| CF.11 | DWARF THIEF | 35p |
| CF.15 | FEMALE CLERIC | 35p |
| CF.32 | LEFT-HANDED FIGHTER | 35p |
| CF.33 | FEMALE FIGHTER | 35p |

ANTI-TYPES

| | | |
|--------|--------------------------------------|-----|
| CT. 3 | RUFFIAN THIEF w. DAGGER | 30p |
| CT. 3A | RUFFIAN THIEF, CLUB & KNUCKLE DUSTER | 30p |
| CT. 3B | RUFFIAN GANG LEADER DRAWING SWORD | 30p |
| CT. 3C | RUFFIAN THIEF w. SCIMITAR & DAGGER | 30p |
| CT. 3D | RUFFIAN THIEF w. BROKEN BOTTLE | 30p |
| CT. 7 | EVIL DWARF | 35p |

ODDS & BODS

| | | |
|-------|---------------------|------|
| CB. 1 | TABLE & TWO BENCHES | 40p |
| CB. 2 | TREASURE CHEST | 30p |
| CB. 3 | DRAGON STATUE | 35p |
| CB. 8 | ALCHEMIST'S LAB | 1.75 |

MONSTERS

| | | |
|--------|---|-----|
| CM. 4 | ZOMBIE | 35p |
| CM. 5 | MUMMY | 35p |
| CM. 6 | WEREWOLF | 40p |
| CM. 7 | WIGHT | 35p |
| CM. 8 | VAMPIRE | 40p |
| CM.10 | TROLL | 40p |
| CM.15 | GARGOYLE | 65p |
| CM.21 | 21G ORCS — ALL TYPES e.g. SHAMAN, STANDARD BEARER, GIANT ORCS ETC | 35p |
| CM.24 | KOBOLD 4 VARS | 25p |
| CM.24A | KOBOLD W. TWO HANDED WEAPON 4 VARS | 25p |
| CM.24B | KOBOLD CHIEFTAIN | 30p |
| CM.24C | KOBOLD SHAMAN | 25p |

THE ABOVE ARE JUST A SELECTION OF OUR 25mm FANTASY RANGES. SEND 30p FOR FULL LISTS WITH DETAILS OF NEW RELEASES AS WELL AS DETAILS OF NEW ORC ARMIES — FROM SMALL GROUPS TO GIGANTIC HORDES

| | |
|--|------------------|
| HOBGOBLIN SETS, 13 FIGS. ALL DIFFERENT | £4.85 SAVE 50p! |
| KOBOLD SETS, 10 FIGS. ALL DIFFERENT | £2.30 SAVE 25p! |
| ORC SETS, 11 FIGS. ALL DIFFERENT | £3.50 SAVE 35p! |
| ORC UNIT SETS, 31 FIGS. ALL DIFFERENT | £10.00 SAVE 85p! |

MAIL ORDER, PLEASE ADD 10% p&p (min. 30p) OVERSEAS PLEASE ADD 33% SURFACE & EUROPEAN; 50% AIRMAIL.

THE FLYING BUFFALO MAIL SALE

With these super offers, you can take advantage of our mistakes in over-ordering. You just won't find better value for money. And all orders over £15 in value qualify for a further 10% reduction. But hurry, we can only maintain these offers WHILE STOCKS LAST.

CARDBOARD HEROES

Set 1 Heroes / Set 2 Brigands / Set 3 Half Orcs / Set 4 Animals / Set 5 Undead / Set 6 Monsters I / Set 7 Monsters II / Set 8 Giants / Set 9 Dungeon Dangers / Set 10 Traps & Treasure / Villains & Vigilantes Heroes / Cops, Crooks & Civilians Heroes / Traveller Heroes 1 Soldiers of Fortune / Traveller Heroes 2 Imperial Marines / Traveller Heroes 3 Zhodani

Normal price £2.95

Sale Price £2.20

SWEDISH GAMES

| | Normal | Sale Price |
|-----------------|--------|------------|
| Dark Passage | £3.50 | £2.50 |
| Southern Flank | £3.50 | £2.50 |
| Ostkrieg | £3.50 | £2.50 |
| Defiance | £3.50 | £2.50 |
| Tau Ceti 2015AD | £2.95 | £2.20 |

ADVENTURE GAMES INC.

| | | |
|----------------------------|-------|-------|
| Tsolyani (2 vols) | £7.50 | £5.95 |
| Adventures in Fantasy | £5.95 | £4.50 |
| Harpoon | £4.50 | £3.15 |
| Deeds of the Ever Glorious | £4.25 | £2.95 |
| Resolution 502 (Falklands) | £3.95 | £2.95 |
| Book of Ebon Bindings | £3.75 | £2.75 |
| Yan Koriani Alliance | £3.00 | £1.99 |

T&T TEE SHIRTS

| | | |
|--|-------|-------|
| Nyaa, Missed My Vital Spots (S or M, please state) | £3.50 | £2.50 |
| Stomach Upset? (S or M, please state) | £3.50 | £2.50 |

Please make all payments (cheque/PO) to Flying Buffalo. Add 10% p&p to all orders. Please allow 14 days for delivery.

FLYING BUFFALO, PO Box 100, Bath St., Walsall, W. MIDLANDS

Make a journey to

Fantasy World

And discover the new shop in the Midlands for all your Science Fiction, Fantasy and War games. Our large stock is still growing, new games are arriving all the time and we are always willing to order any items not in stock. Our two floors also contain American and British: Science fiction paperbacks, comics, posters, film stills, fantasy art books, film and rock magazines, plus much more!

'Fantasy World' is open Monday to Saturday, 10.00 am till 5.30 pm and is easily located in the middle of Hanley city centre, at 10 Market Square Arcade. The entrance and escalator up to 'Fantasy World' is in Lamb Street, opposite Lewis's. Hanley Bus Station and Stoke-on-Trent Railway Station are just minutes away. If you are travelling by car, there are plenty of car parks available and junction 16 of the M6 Motorway is only 20 minutes away via the A53 and A500!

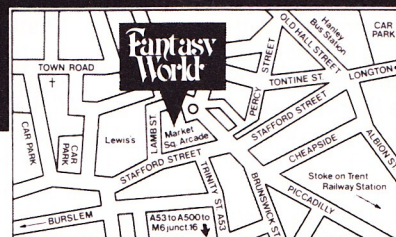

Closed all day Thursday

10 Market Square Arcade, Hanley, Stoke-on-Trent.

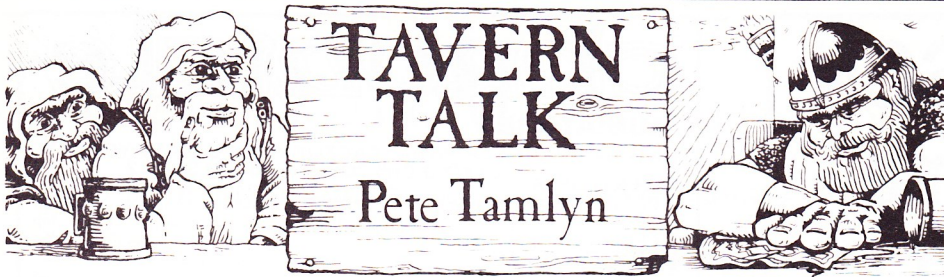

Well it had to happen sooner or later. With **Acolyte** running to five-weekly deadlines and **IMAGINE™** magazine to monthly ones, the time must arrive when the two come into conjunction. Quite what the astrological significance of this is I'm not sure, but the effects are fairly drastic. Here am I, rushing around trying to get my 'zine out on time, and I suddenly remember that I have to do a Tavern Talk as well. Ah well, things could be worse. When you're reading this, and my deadline for issue 8 comes around, I'll be somewhere in the wilds of Scotland on my honeymoon. Gods only know what I'll write about then, but I doubt that it will be FRP!

Anyway, to business, it's apology time. Remember issue 3's letter column? Awful, wasn't it. I expect most of you sat there aghast, wondering who these idiots were and why they were so fulsome in their praise of my witterings. The answer is simple: they were all fanzine editors, and the reason they were buttering me up so much is that they want me to mention their names and 'zines in this column. Tough: anyone wanting their names dropped here has to do something newsworthy, and with the departure of Marc Gascoigne there are precious few personalities to gossip about. They are trying hard, though. Matt Quarterbrain has managed to make himself notorious by turning up at The Lamb and talking louder than anyone else and Steve Norledge of **Tempestuous Orifice** seems to be a graduate of the Brian Dolton School of Self-Publicity through Copious Letter-Writing. But in search of really good copy I have to turn once more to the postal games hobby.

Pete Doubleday is crazy. Subscribers to his fanzine will know this already. Its title, **The Thing on the Mat**, has that special, Lovecraftian air which suggests not only the unspeakable, indescribable and unnameable (good phrase that, Mr Langford), but quite possibly the unreadable as well. It is, by which I mean that I find it, difficult to read more than a few pages without collapsing with laughter. **Thing** isn't to everyone's taste — Doubleday has such elegant command of the seamier side of the English language that the 'zine acts as a +5 **amulet of protection** vs members of the Moral Majority — but it is crazy, because Doubleday is, because I have the proof.

Picture, if you will, an 'hard working' history student at Oxford just about to sit his finals. And history finals at Oxford are

still serious — 100% of your degree rests on them. Under those circumstances, most editors would give their 'zines a rest. Not Doubleday — he put out a normal issue (if **Thing** could ever be called 'normal'). Why? Because he's crazy, and because he had something to tell people — he stood for Parliament. Now Polling Day was just two days after his last exam, so campaigning and revision went hand in hand. I repeat, he's crazy. Unfortunately, the good burghers of Oxford were not over-enamoured with the candidate of the Cerebus the Aardvark party and awarded him so few crosses that my newspaper saw fit only to lump him together with two fellow eccentrics as 'Others' with only 207 votes between them. Obviously the world is not yet ready for the concept of fanzine editors in Parliament. But people should be more kind to lunatics, don't you think?

In the interests of public safety I am not allowed to give an address for **Thing** on the Mat. Besides, Doubleday has a frothing hatred of all things role-playing, matched only by his frothing hatred of everything else in the world except Bruce Springsteen and Phillip K Dick. If you're really interested you'll find the address in **20 Years On**.

Remember my comments about the profusion of ™ and © signs that adorn the names of TSR products? Well the sarcastic comments continue to gush forth in fanzine reviews of **IMAGINE** magazine. One that caught my eye was this piece by John Harrington in **Take That You Fiend**: 'the constant "hands off" warnings after every mention of TSR-related products destroys the friendly ambience created by the rest of the publication. There is, I feel, an implied condemnation that anybody who plays an FRP game by any other company is a witless heretic'. Now I could say, 'What do you expect from someone who plays **Tunnels and Trolls**', but Chris Harvey would sue me and anyway I think TSR's marketing department could do with the feedback.

Finally, with **Sol III** having come and gone, and got itself onto Radio 1's 'Platform 9', reducing Janice Long to hysterics at the mere thought of Trekkieism in the process, an idle thought occurs to me. Is it not time we had a proper FRP fan convention? I mean, GamesFair is all very well, but we can't expect to rely on 'Uncle Don's' generosity for everything. SF fans can do it, Diplomacy players can do it. Why not us too?

 Pete Tamlyn

Letters

IMAGINE™ magazine invites its readers to write on any subject that might be of interest to other adventure gamers. Correspondence should be addressed to **IMAGINE** magazine (Letters), The Mill, Rathmore Road, Cambridge CB1 4AD. Letters appearing in this column are edited for length.

We have provoked a fair amount of comment on the thorny subjects of role-playing, realism and rules:

R. Stevenson, Essex: Of all the role-playing games I've played, not one can truly get you in a role-playing mood unless you are fortunate enough to know talented DMs or put in the amount of effort needed to be in harmony with the game. **Runequest** and **Tunnels & Trolls** succeed in cutting down game mechanics to the minimum so you can get on with the actual role-playing.

Mike Lewis, Broadstairs: The reason I said that the **AD&D™** game wasn't a *role-playing* game is because, if played to the letter of the rules it can't be. I would define an RPG as a game where the player is free to play a character with full depth of role visualised, with actions taken by the character depending on that character's make-up, emotions etc.

Taking **Advanced** to the letter of the rules and playing it with all official rules such as alignments, character classes, etc it is not a role-playing game by the above definition. A player does not play a unique character but has a choice of a

meets...clubs & hobby meets...clubs & hobby meets...clubs

Clubs & Hobby meets

Rowan Wilson, of 7 Rozledene, Hindhead, SURREY GU26 6TW, telephoned to ask us to enquire if players in the **Guildford** area if they are interested in setting up a gaming club. Rowan is particularly interested in the **Traveller** game, but any RPG would do. Anyone who thinks it might be a good idea, should contact Rowan at the above address.

The Phantasmal Forces Fantasy Group meets every Thursday night at 7.30pm in the **NALGO** club, 20 Lord St. West, **Blackburn**. The 'informant' in this case was one Smurf Esq, who gives his mate G. Pearson (tel: Blackburn (0254) 665898) as contact.

A new contact has been announced for the **Glasgow** hobby meet, previously advertised in this column. Wallace Nicoll, 194 Hawkhead Road, Paisley, Glasgow (tel: 041-889-7042) has all the details.

And there is now a second **London** 'meet, Beastmeet, at the 'Duke of Argyll' in Brewer Street, Piccadilly, on odd Fridays. Contact Brian Dolton, 94 Waddington Avenue, Old Coulsdon, Surrey CR3 1QN.

Fanzines

Another look through our monthly collection of assorted publications from the amateur end of the hobby. Other editors should note that the only thing stopping their zine being similarly exposed is the fact that they never send us a copy.

Mad Policy 85 announced a price rise. Richard Walkerdine, 144 Stoughton Road, Guildford, SURREY GU2 6PG has had to put the price of later issues up to 18p. Has the Zine Poll cost so much? It seems to have dropped Richard into trouble over the eligibility rules he announced for the poll. Mad Policy runs Diplomacy, Formula 1 and Finchley Central (sic).

Gazfinc 2 came in the same envelope, although it is now independent. This is *the* place to play Finchley Central, and *the* place to find out what the game actually is.... 10p from Richard Bairstow, 20 Queen's Drive, Guildford GU2 6PP.

Acolyte 48 arrived on time, even though Pete Tamlyn found himself writing it and his column for this magazine on the same weekend. His article on paganism in 47 has stirred up some flak; in fact the letters column is great reading. This is the issue where Ian Marsh showed that he is a TSR lackey in the making. Diplomacy, Sopwith, and many other games from 6 Broughton Close, Birtton, Aylesbury HP22 5DJ.

Take That You Fiend 8 has stolen the Acolyte style of having the games material in a separate section, clearly a sign of a weaker stapler, since Acolyte is thicker. The election post-mortem and FRP ideas are separated by a swiping review of IMAGINE™ magazine, particularly the bits that say™ and®. John Harrington, The Porch, 82 Hacton Drive, Hornchurch, Essex RM12 6DP sent it to me; send 35p and help him buy the rest of his house.



Walamalaysia Gazette 31 is pretty thin. An En Garde zine with only 5 pages of reading matter from Dave Thorby, 200 Lavender Hill, Enfield, Middlesex.

War Machine 19 continues its useful service to the micro-fans. Reviews, tips and programs from Mike Costello, Emjay, 17 Langbank Avenue, Rise Park, Nottingham NG5 5BU; £12 annually for 12 issues. A useful zine. And from the same address....

Wargame News 6 tries to offer the same service to wargamers. £7 for 12 issues. Joint subscriptions are available.

Psychopath 7 shows continuing style. An En Garde, El Nabisco zine from Mike Dean, Rm38b West Park Hall, 319 Perth Road, Dundee DD2 1NN for 35p. The letters column is spicing up nicely, and the GamesDay North review was neatly done. Worth a look.

Zine To Be Believed 14 concerns itself most with developments in the hobby, and with its myriad Diplomacy, 1829, and others from Nick Kinzett, 11 Daleway Road, Green Lane, Coventry CV3 6JF.

Greatest Hits 108 wins the award for journalistic coup of the month with 'Irving Goes To GamesFair', a blow-by-blow account of the Reading event, and very funny. The coup? Well, as I remember, Irving didn't arrive until the middle of Sunday afternoon, so he missed 80% of it. Pete Birks, 39 Handforth Road, London SW9 0LL knows how he did it.

NMR 40 arrived from Brian Creese, 256 Canbury Park Road, Kingston, Surrey KT2 6LG. Brian is the latest recruit to our posse of contributors and the results of his labours are on page 36. If you were that impressed NMR has hobbynews, the pub guide part 10b, reviews, letters and Diplomacy and Railway Rivals among the games.

Hopscotch 32 comes from Alan Parr, 6 Longfield Gardens, Tring, Herts HP23 4DN, the latest recruit to somebody else's posse of contributors. Alan is going to be writing for **Games Gazette**, which must prove a good step for that magazine. Why didn't we get him?

Astradyne 60 closed off a successful Soccerboss season. Just like Jimmy Hill, Ian Lee (49 Fleet Avenue, Upminster, Essex) will be back before you know he's gone.

Ansible 33 shows that gaming fanzines aren't the only ones to have polls where outsiders can't understand any of it. If you're interested in the fan end of SF, contact Dave Langford, 94 London Road, Reading, Berkshire RG1 5AU.

Fantasy Advertiser 79 is excellent value for comic fans at 40p. Forthcoming comics, reviews, news and a RPG column; from Martin Lock, 3 Marlow Court, Britannia Square, Worcester WR1 3DP.

Lastly, our new membership of the British Science Fiction Association (£7 pa) has brought us **Vector 114**, the critical journal of the BSFA, **Paperback Inferno vol 6, no 4**, a review vehicle for SF paperbacks and **Matrix 47** which itself proved that gaming fanzines aren't the only ones with funny names. **Fandom of the Opera?** Details of the association from Sandy Brown, 18 Gordon Terrace, Blantyre, Lanarkshire G72 9NA.

♣ Paul Cockburn

EUROPEAN ILLUMINATI™

New ideas for the popular game, by Geof. Hogan and Cathy Pash

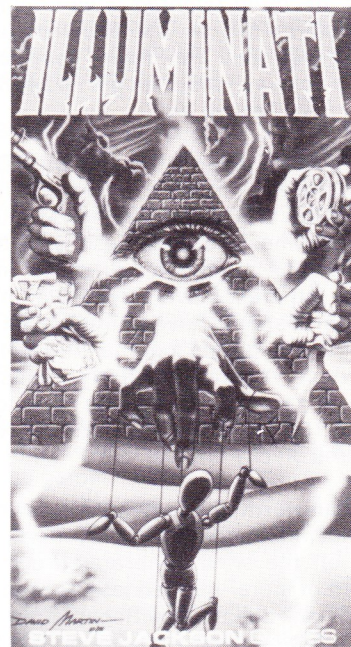

Illuminati, the game of world conquest by stealth and guile has become quite a successful product for Steve Jackson Games of Austin, Texas. It offers just the right mixture of good old-fashioned competition and plain stupidity that enthral gamers everywhere. But for us cultured Europeans it contains a problem. All those Americanisms.

It isn't cards like *Democrats* or the *FBI* that cause the problem — I mean, we all read the *Grauniad*, don't we — but what is the *Fred Birch Society*? What happened to the Unions, the Railways, the Game Companies?

Geof. Hogan and Cathy Pash have come up with the answer — the European **Illuminati**. Completely compatible with the existing game; these new cards give a new flavour to the complex chains of control that typify any session of world domination. We don't claim that these offerings are the complete answer, nor do we claim that Steve Jackson has lost sleep worrying about their effect on Trans-Atlantic relations, but you can give them a try in the privacy of your own bunker, and perhaps you can think up a few ideas of your own. We were disgusted that the GLC weren't allowed to give money to Weird groups anywhere on the table and that TSR wasn't even mentioned! Let us know what you think they missed.

IMAGINE™ magazine gives permission for the opposite page to be reproduced for gaming purposes.

THE SAMARITANS
R=0 for weird groups

Resistance 4
Income 1



Peaceful
Straight

THIRD WORLD
Communist or Govt. attack at +4

Power 4
Resistance 6
Income 4



TRAINS

Power 0/2
Resistance 4
Income -1



Government

THE VATICAN
+4 to control/destroy I.S.A.

Power 6/4
Resistance 6
Income 6



Straight
Peaceful
Conservative

GAY LIBERTARIANS
+2 on any attempt to control moles

Power 2
Resistance 4
Income 1



Liberal
Weird

LIONS OF LONGLEAT

Resistance 1
Income 3



Weird

THE MOLES
+2 on any attempt to control Govt.

Resistance 6
Income 2



Communist
Fanatic
Liberal

SPECIAL EVENT
Royal Wedding/Birth/Anniversary

All other players miss one turn and pay player of card 2MB for souvenirs

ETHNIC RIOTERS
+2 to destroy Govt. (any attempt)

Resistance 4
Income 0

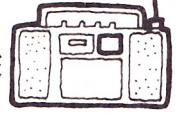

Violent
Criminal

CHARITIES
Money on card may be used to finance another card's attack

Power 0/2
Resistance 4
Income 1MB from each player



IRISH SECTARIAN ARMY
+2 to influence Republicans or Democrats (any attempt)

Power 4
Resistance 6
Income 4



Fanatic
Violent
Criminal

SPECIAL EVENT
Recession

All other players reduce income by half for one turn. Oil multi-nationals disassociate

BRITISH FILM INDUSTRY

Power 1
Resistance 4
Income +3/-5 (50% chance)



Liberal
Peaceful

THE G.L.C.

Power 4/3
Resistance 3
Income 4

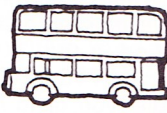

Government
Weird
Liberal

LANDED GENTRY

Power 3
Resistance 6
Income 6



Conservative
Fanatic

LOBBYISTS
+2 on any attempt vs. Govt.

Power 2/2
Resistance 5
Income 2



Peaceful
Straight

OLD SCHOOL TIE
+2 on any attempt to control Govt./Straight

Power 2/2
Resistance 6
Income 4



Conservative
Straight

DR. WHO
+4 on any attempt to destroy Trekkies without need of Whispering Campaign

Resistance 1
Income 1



Peaceful
Weird
Fanatic

THIEVES' WORLD: RPG playing aid

This is, without doubt, the most comprehensive RPG playing aid that I have seen. The box contains three maps and three booklets; the maps show the city of Sanctuary, its streets and buildings, and then large scale detail of one particular area, the Maze, and its underground labyrinth of cellars, sewers and tunnels. The booklets are: the Games Master's Guide, containing plans of the more important buildings, fairly comprehensive encounter and incident tables and some notes on the organisation of the city itself; the Players' Guide, containing a less detailed map and notes on the structure of the city, its history and development, and its prominent citizens and transients; and Personalities of Sanctuary, containing notes on nearly 100 characters and statistics for nearly 40 of the major inhabitants, transients, gods and monsters formatted for nine different RPG systems (DUNGEONS & DRAGONS™, both Basic and Advanced, Adventures in Fantasy, Chivalry and Sorcery, Dragonquest, The Fantasy Trip, Runequest, Traveller, Tunnels and Trolls). There are not many monsters (non-human, that is) and those that do exist are under the control of the gods or principal magicians.

But what is Sanctuary? Well, first, what it is *not*! It is not an ity-pretty fairytale town of honour-bright heroes, beautiful princesses and wicked, but easily defeatable, villains. The detailed descriptions of place and character show a decaying, medieval

type of city with all the problems associated with a subject people of the edge of a military empire. There is bribery, murder, drug addiction, prostitution and all types of fraud and petty crimes; there are gangs both of adults and of children; there are the forces of law and order and the powerful factions of smugglers, merchants and organised crime; there is the wide gulf between the rich and powerful and the poverty stricken and desperate. There is an ambitious and energetic middle class, itself subdivided many times. There is magic of several kinds as well and many charlatans practising upon the credulous.

The true adepts are a curiously mixed and dangerous group and adventurers would do well to remember the adage, 'meddle not with the affairs of wizards for they are subtle and swift to anger!' The gods themselves are very active in Sanctuary with frequent clashes between the various mythoses, especially those of the ancient kingdom and the empire.

One thing that should strike the players in a scenario involving Thieves' World is that although there is much crime, law and order is very much in charge. Be it the official law of the empire, the various religious or merchants' courts or just the rough justice of the streets, custom is important and breaking the rules, written or unwritten, requires payment, of just money if fortunate, but often with fingers, whole limbs, bodies (if sold into slavery) or even lives.

For a fuller picture of the city and its people, the Thieves' World series of books edited by Robert Asprin cannot be too highly recommended: there are four at present, 'Thieves' World', 'Tales from the Vulgar Unicorn', 'Shadows of Sanctuary' and 'Storm Season'. They are published by ACE but, being American imports, are only available from a limited number of retail outlets; the only one I know of is Forbidden Planet, 23 Denmark Street, London WC2, but there must be other sources about the country.

There is plenty of information in this pack for the DM to make a really first rate and exciting city for the players, fleshed out by their collective imaginations and perhaps coloured by the books, if you can get them. The set may seem a little pricey — what isn't these days? — but it is worth every penny.

J C Conner

Thieves' World, a boxed set with three maps and three booklets, is published in the USA by Chaosium Inc and is distributed in this country by Games Workshop, 27-29 Sunbeam Road, London NW10 6JP. Price £14.95.

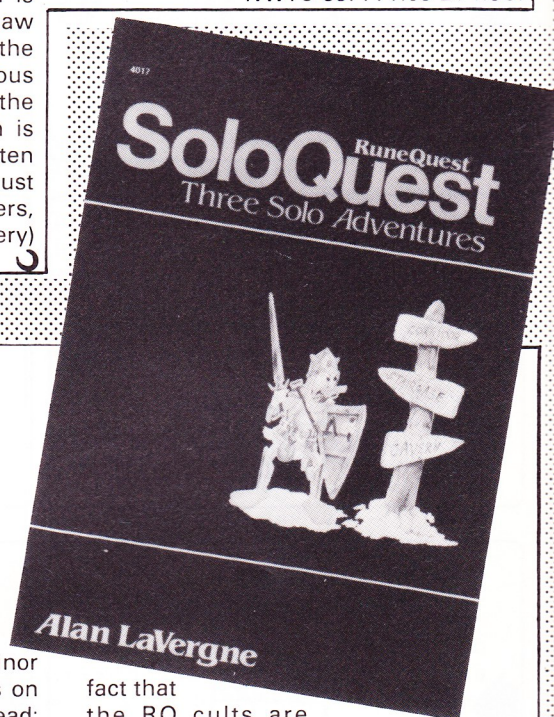

SOLOQUEST

Soloquest is the first solitaire adventure book for Chaosium's **Runequest**. The three adventures contained in the book, namely 'Dreamquest', 'Phoney Stones' and 'Maguffin Hunt', offer a good selection to start the series.

In 'Dreamquest', the character is offered the chance to re-enact the conquests of his or her god (characters of experience 50-60% are most suitable).

As the name implies, these quests take place in the land of dreams, where the character will face four randomly chosen foes, each of which has preset instructions, eg 'Attack anyone who is not a Tusk Rider. Be friendly to Elves.' These serve to give variety to any subsequent adventures with different characters.

After successfully completing four Quests, the character must face a special foe, which should be enough to guarantee that few survive. Those

who win through the Dreamquest are rewarded by the god, those who fail lose POW and have to wait a year before trying again.

In 'Phoney Stones', characters are asked to find out who is selling false statues of Issaries. This adventure requires more than a little thought and is most enjoyable. One minor error I did find in the UK printing is on page 47, section 716, which should read: 'If he befuddles you, go to 717.' A thinking player with a character of 60% experience should find the culprit. I didn't...

The last adventure, 'Maguffin Hunt', sets you out to recover the stolen Maguffin, and to bring back the culprits who stole it (dead or alive). This is the toughest of the three adventures — characters of less than 60% will meet their makers pretty soon. As with 'Phoney Stones', it is suggested that you run through this adventure once only.

All in all, Soloquest offers good value for money. I have just one reservation; the

fact that the RQ cults are referred to frequently, but the book carries no warning of this. If you haven't got the **Cults of Prax**, it will lessen the entertainment value offered by this book.

This apart, Soloquest is a nice addition to the Runequest family. I look forward to the sequels.

Trevor Graver

Soloquest, a Runequest solo adventures book is available from Games Workshop, 27/29 Sunbeam Road, LONDON NW10 6JP. It costs £4.50. Reviews of Soloquests 2 and 3 will follow shortly.

Distributors' names are given for information only.

DRAGONHUNT



This simplistic 2 to 6 player fantasy boardgame is based around the kingdoms of Arawan, which have long been terrorised by Brimstone the Dragon. Each player aims to control a kingdom by using its resources to slay Brimstone, and only wins when this is achieved. First the Dragon must be wounded three times, and conflict between players will occur simply to prevent someone else killing Brimstone first; there is little scope for player co-operation.

The concept behind **Dragonhunt**, and its excellent, colourful physical presentation create a pleasing first impression which is maintained during the first few moves. But sadly this is not sustained deeper into play when the problems of the game system become noticeable.

There are good points. These include the intricate sequence of play which meshes well, enabling smooth, prompt, turn-rotation. Then there is Brimstone who, conceived as a Smaug-like dragon, makes a fine game monster. Its movement is influenced by each player except when it is enraged; at this point it becomes uncontrollable and moves at random. Dragon combat is always unpredictable, which is good. The climactic death-battle between Dragon and hero/knight is well staged using a different combat system, with the Dragon having the slight edge.

Another credit is the 10 'fantastic-beings'. Each has unique attributes, and players vie for control of them so as to use these special abilities to their advantage. Thus the 'beings' tend to have a major influence on play.

Unfortunately player-units are not so well handled. Players select a card numbered from 7 to 12 to decide who goes first, the lowest untied selection gaining this advantage. The problem with this is that the selected card represents the total number of movement points a player can expend between his or her entire force of 41 units. This is completely inadequate. It results in most units never being moved

and makes the mounting of a campaign nigh impossible; and virtually forces players to move their strongest unit, the hero, and to conduct solo raids with him.

Naturally, this adversely affects the player unit combat system, which is poor anyway due to the many irrationalities arising from certain rules. Some rules treat units as individuals, while others treat them as a mass of men. Furthermore, a player of greater strategic ability cannot bring weight of numbers to bear, for all 'battles' are single unit duels which tend to be even affairs resolved by lucky die rolls. This gets extremely tedious, for there is just nothing of 'heroic fantasy' about it.

There are other problems: the concept of cottages is nonsensical, as they can never be attacked as hostile units, even though units inside can attack out, and wounded units are instantly teleported to their home cottage to be instantly healed. The rules are not entirely solid and contain some shady areas, and doubt can be cast on the acceptance of Arawan as a fantasy realm. Overall there is too much stylisation, the hallmark of an abstract rather than a fantasy game. Each kingdom is composed of a castle, village and cottage of exactly the same shape, and set symmetrically around the map edges; players start equal, have the same countermix and the same objective. The end result is that there is no individual character and identity to the kingdoms; they lack soul.

The designer's notes state that '**Dragonhunt** is more than just a game, it is a real fantasy experience...' This is true, but unfortunately, given many of the inconsistencies, play mechanisms and concepts, there is too much fantasy in the worst sense of the word.

 Robert Hulston

THE LEGEND OF ROBIN HOOD

Before an examination of the game itself, it might be useful to take a look at what you get for your money:

The game is packed in a convenient 6" x 9" box with fairly average artwork. The playing board is rather neat in that although it is 17" x 22" it comes in one piece; this is achieved by having folds and cuts in the right places. The idea seems to work, but how it stands up to repeated use remains to be seen. The artwork on the board is good, and a useful feature is the inclusion of tables around its edge — a notable exception, however, is a chart showing the sequence of events in each turn. The counters are the usual cardboard ones. Although the inclusion of a die is noted on the box, this is absent. Instead, you are provided with numbered counters and instructed to draw them out of a cup!

The game itself is for two players. One, as Robin Hood, must fulfil three out of four listed victory criteria such as marrying Maid Marian or reducing the sheriff's treasury by robbing rich nobles or bishops who pass through the land. The sheriff player must endeavour to stop him, and wins if he can do this until turn thirty, or kills Robin before then. An average game lasts between one and two hours.

Provision is made within the rules for most of the elements contained in the Robin Hood stories, eg the taxation of villages by the sheriff, the archery contest, capture, ransom and killing of leaders, Robin's combats with Little John, Will Scarlet and Friar Tuck before they are recruited to his cause, and the return of King Richard.

Initially, the sheriff player has the upper hand, because Robin must recruit the other outlaw leaders and 'merry men' to his cause. The tables are turned later in the game, however, with Robin having a slight advantage. Combat occurs when two or more opposing units are in the same box. It is resolved quickly due to drastic combat tables, but it is designed to mimic battles by having archery, melee, and personal combat phases.

The Robin Hood stories could be resolved into a good game — I would not say this was it, but if you like two player games, this one is not bad.

 Mike Dean

Dragonhunt and Robin Hood are both supplied by Avalon Hill, 650 High Road, North Finchley, London N12 0NL. **Dragonhunt** costs £11.95 and **Robin Hood** costs £4.95.

These games are available from hobby shops.

MINIATURES

TORCHLIGHT FANTASY PRODUCTS

With the amount of attention that has been lavished on producing figures for the D&D® game market over the last few years, it is surprising no-one has thought of providing three-dimensional dungeon accessories before now; now that they *have*, it seems to have occurred to several manufacturers at the same time!

Torchlight's range comprises a series of dungeon kits cast in white resin, which can be assembled to make realistic scale dungeons — minus roof, of course, to facilitate play. Each pack contains an area of floor, two inches wide for a corridor,

more for a room, and appropriate wall length. The floor is grooved to allow the wall to be stuck in place, and each piece is sculpted to represent stone slabs or flagstones.

The variety of pieces available is sufficient to allow for most possibilities, and when assembled and painted the sets do look most attractive, and the corridors are wide enough and the walls low enough to allow figures to be moved quite easily.

Prices vary from 60p for two 2" x 2" floor spaces minus walls, to £5.75 for an 8" x

8" 'master chamber' set with full accessories. Also from Torchlight is a selection of assorted treasure chests, bones and other dungeon debris, cast in resin but in much the same style as their metal counterparts and considerably cheaper. In all, a very useful range which will add a degree of visual realism.

Ian J Knight

Torchlight Fantasy Products can be contacted at 23 Clifftown Road, Southend on Sea, Essex, to find out which is your nearest stockist.

ESSEX MINIATURES

Essex Miniatures have established an enviable reputation in the field of 25mm historical figures, and they've now turned their attention to fantasy subjects. As yet their range is limited to a selection of adventurers, one or two exotic monsters and a small tribe of dwarfs, but the quality is sufficient to whet the appetite and raise hopes for more to come.

Among our samples were a very nice, clean-lined Centaur, firing a bow, a magic user with staff and large spell-book, and a selection of dwarfs. The latter came in a

variety of poses, carrying assorted swords, hammers and cross-bows and dressed to varying degrees in armour.

The general sculpting style is similar to Citadel, with plenty of rascally character, notably one pot-bellied, bearded fellow with a cross-bow, hat set at a jaunty angle, looking like a cross between a sixteenth century German mercenary and something from *Snow White*! The command set was particularly inventive, especially the standard-bearer wielding a huge boar's head on a pole.

Prices vary from around 26p for a single figure to 65p for a pack of three dwarfs. My only complaint is that the bases on some of the figures are a little small — the Centaur is very unsteady and apt to overbalance. To those of you accustomed to mounting figures on card bases this will not, however, be a problem.

Ian J Knight

The Essex Miniatures catalogue is available from 3 Bay Close, Canvey Island, Essex SS8 0AF.

CHRONICLE FIGURES

Our latest samples from the ever-prolific **Chronicle** include a selection from their Hobgoblin range, already so comprehensive that you can build up a fair sized war band without duplicating a single figure.

The first thing that strikes you is their sheer *presence*. They have a bulky, squat, powerful look, loaded with beefy menace, which is hard to ignore. Everything about them seems solid, from the muscular physiques, just visible between the plates of thick iron armour and weighty chain-mail, to the long, heavy, slant-eyed, pug-nosed brutal faces. There is a clarity of definition about the sculpting and the casting which makes every rivet in the armour and every stud in the shield seem remarkably real.

Modelled in a variety of lumbering poses, they are indeed fearsome adversaries, armed with a frightening selection of broad, short swords, spiked clubs and polearms. Chronicle's figures tend to be chunkier than the slim, more delicate American-style models of some other manufacturers, and in this range it could scarcely be more appropriate. The Hobgoblin chieftain is a real gem, dwarfing his underlings, posed with his shoulders hunched, head thrust forward, teeth bared in a bad-tempered snarl, a huge sword in each hand — excellent!

Marginally more genteel are some of the additions to Chronicle's other ranges, including a half-orc adventurer, poised to swing an axe, and laden with a convincing array of back-pack, daggers, shield and

other accessories; a rather energetic mummy; and a suitably repulsive wight, bent double nursing a sword that has seen better days and thrusting out a sunken-eyed skeletal face.

Considering the amount of detail and the many deep undercut, Chronicle's figures are remarkably free from flash or casting lines. They've developed a very distinctive character of their own, and the quality seems to improve with each new release. Thoroughly recommended.

Ian J Knight

Chronicle can be contacted at Unit 14, Engineer Park, Factory Road, Sandycroft, Clwyd CH5 2QD for details of products and suggested purchase sources.

RUNEQUEST CHARACTER/ADVENTURE SHEETS

Another goodie for Runequest players: the character sheets are loosely based on the Sapienza Mk 4 character sheet (which appears in all editions of the RQ rulebook). These sheets are laid out with ease of play in mind; block lines help to separate different sections of the sheet, the weapons section has been sub-divided so that missile weapons and shields can be found quickly.

The adventure sheets — which come four to a sheet — are used to save messing up your nicely documented character sheets. Whenever you go adventuring, transfer the basic stats

onto an adventure sheet and this will save countless erasings or crossings out as you lose HPs or POW, thereby giving extra life to the character sheet.

One minor glitch appears on the sheets; the hit location rolls for R and L arm have been reversed (they are missing altogether from the adventure sheets!). This could lead to confusion until you decide which charts to use. Runequest Character/Adventure Sheets are sold together on a pad of 30/80 sheets and work out a lot cheaper than photocopying. They look nice too!

Trevor Graver



THE SWORD OF ALABRON

By: Ian Williamson

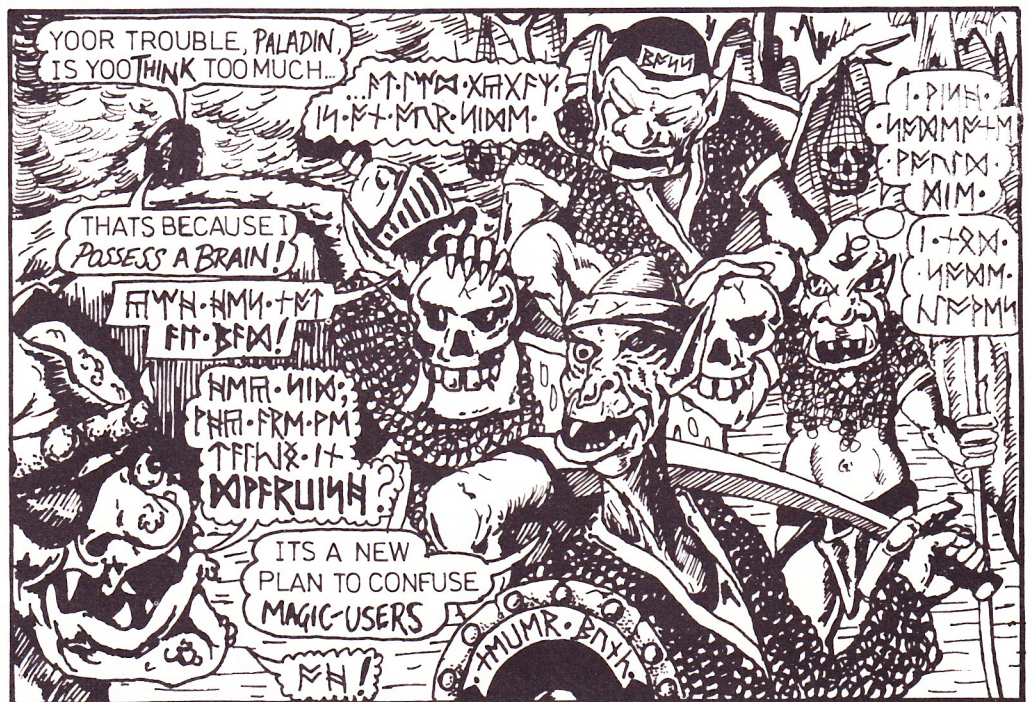

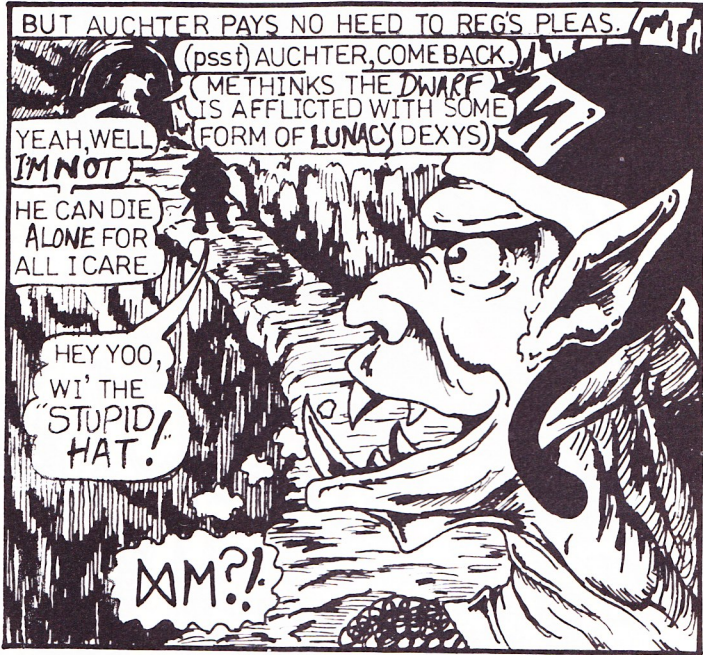

BUT AUCHTER PAYS NO HEED TO REG'S PLEAS.

(psst) AUCHTER, COME BACK.

(METHINKS THE DWARF IS AFFLICTED WITH SOME FORM OF LUNACY DEXYS)

YEAH, WELL I'M NOT

HE CAN DIE ALONE FOR ALL I CARE

HEY YOO, WI' THE STUPID HAT!

MM?!

THE ORC PATROL HAVE HAD A HARD DAY. NOW INSULTS LIKE THAT TO 'GOBNOXXIOUS' (CHIEF 'LAD', SO TO SPEAK) USUALLY RESULT IN A SWIFT DECAPITATION, ORC OR NO ORC, TO SAY THE LEAST! BUT TO HAVE BEEN UTTERED... BY A DWARF!!



ITN.F
RMTTM+
XIPFRY...
"WIT-IT!"

Bounce!
Bounce!
Bounce!

TRY SAYIN' THAT AGIN WI' A MOUTHFUL OF THIS AXE!!



HOWEVER, THE CAVALRY ARRIVES.

GREAT, THAT SCENE HAD TENSION, CONFLICT EXCITEMENT... ALMOST EVERYTHING!

...EXCEPT, NO-ONE OUT THERE CAN UNDERSTAND YOU

MM?

WIZZ

SO CAN WE TAKE THAT AGAIN? THIS TIME IN COMMON...

'STINNED' INTO THOUGHT GOBNOXXIOUS HAS ANOTHER GO! FRAME 6, TAKE 2



ER! YEAH... RIGHT... "ITS A..R..RO ROTTEN.. DW..? DWARF ..K..K..KI.."

KILL..(what does the last word say?) SLIME? SL..SLA?..

BOUNCE

SLAM™

TITAN DISTRIBUTORS LTD.

WHOLESALE &
DISTRIBUTORS OF

STAR WARS - toys · figures · kits · etc

E.T. - toys · merchandise

BLADE RUNNER - cars · filmbooks · etc

SCIENCE FICTION BOOKS - British & import

U.S. and U.K. COMICS

ILLUSTRATED FANTASY ART - books · p/folios

TITAN BOOKS - comic art albums

JUDGE DREDD - game · badges · figures · etc

2000 A.D. - books · candles · T-shirts

DR. WHO - books · merchandise

TRON - toys

JAPANESE ROBOTS

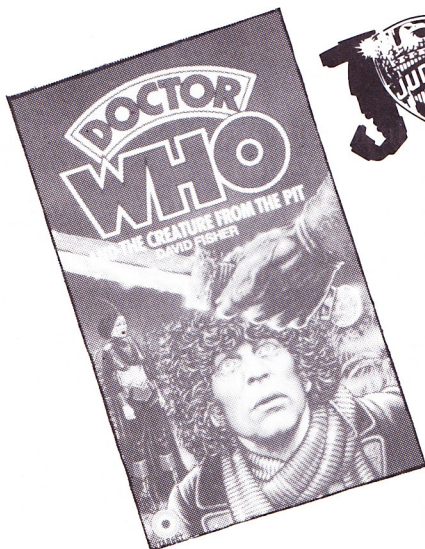

P.O. BOX 250, LONDON E3 4RT, ENGLAND.
01-980 6167/8 FOR DETAILS.

Please mention IMAGINE™ magazine when you reply to advertisements

**NEW
POPULAR
EDITION**

**COMPLETELY
REVISED**



DUNGEONS & DRAGONS® BASIC SET

The Original Fantasy Role Playing Game

“Your first step on the road to Adventure!”

This is a game that helps you imagine.

“As you whirl around, your sword ready, the huge red fire-breathing dragon swoops TOWARDS you with a ROAR!”

See? Your imagination woke up already. Now imagine: this game will probably be more FUN than any other game you've ever played!

The DUNGEONS & DRAGONS® game is a way for us to imagine together—like reading the same book, or dreaming the same dream. But it's a book that YOU can write, without putting a word on paper — just by playing a D&D® game.

This New Popular Edition has been completely revised to include ONE-PLAYER GAMES as well as group games for Players and Dungeon Masters. YOU can start playing RIGHT AWAY!

- Programmed adventures for easy learning and HOURS of FUN
- The PLAYER'S GUIDE for beginning characters—with simple and expert combat rules, magic spells, and role playing tips
- The DUNGEON MASTER'S HANDBOOK—full of treasures, monsters, and dungeons
- All the Dice you need — Six different kinds included, with marker crayon

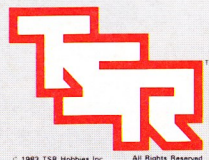

© 1983 TSR Hobbies Inc. All Rights Reserved

TSR UK Limited
The Mill Rathmore Road
Cambridge CB4 1AD
Telephone Cambridge 0223 212517